

SEMI-AUTOMATIC STRAPPING MACHINE



GPSAS-303 OPERATION MANUAL

2022-02-16

1



EC Declaration of Conformity

According to the following EU Directives:

- Machinery Directive: 2006/42/EC
- Low Voltage Directive: 2014/35/EU
- Electromagnetic Compatibility Directive: 2014/30/EU

We, [EXTEND GREAT INTERNATIONAL CORP.](#)

[Add: 20F, No. 309, Sec. 2, Taiwan Blvd., Taichung, Taiwan R.O.C](#)

[Tel: +886-4-2326-5568](#) [Fax: +886-4-2326-2268](#)

Declare that the machines mentioned hereafter:

☉**Product: Strapping Machine**

☉**Model: EXS-303**

☉**Serial No.:**

☉**Functions: They are used for packaging products by polypropylene strap**

They are designed and manufactured in compliance with the essential health and safety requirements of the Machinery Directive and Electromagnetic Compatibility Directive, and are based on the following European harmonized standards:

- EN 415-1:2000+A1:2009, Safety of packaging machines - Part 1: Terminology and classification of packaging machines and associated equipment
- EN 415-8:2008, Safety of packaging machines - Part 8: Strapping machines
- EN ISO 12100:2010, Safety of machinery - General principles for design - Risk assessment and risk reduction
- EN ISO 13849-1:2008, Safety of machinery – Safety related parts of control systems Part 1: General principles for design
- EN 60204-1:2006+AC:2010, Safety of machinery - Electrical equipment of machines - Part 1: General requirements
- EN 55011:2009+A1:2010, Electromagnetic compatibility - Industrial, scientific and medical (ISM) radio-frequency equipment- Radio disturbance characteristics- Limits and methods of measurement
- EN 61000-4-2:2009, Electrostatic discharge (ESD)
- EN 61000-4-4:2012, Electrical fast transient/burst requirements (EFT/Burst)
- EN 61000-4-6:2014, Immunity to conducted disturbances, induced by radio-frequency fields (CS)

Authorized representative in European Community: (if applicable)

Representative: _____

Robert Lai / President

Place / Date :

Taichung City, Taiwan. / April 22, 2016.

1 GENERAL SAFETY INSTRUCTIONS

1.1	Basic Operation	5
1.2	Basic Safety Precautions	5
1.3	Safety Instructions Governing Specific Operational Phases	6
1.4	Warning of Electrical Dangers	7
1.5	Grounding Instructions Shall Include the Following	8
1.6	Before Operating	9
1.7	During Operation	9
1.8	After operating	9
1.9	Signs	10

2 MACHINE INFORMATION

2.1	Areas of Application	11
2.2	Environmental Information	11
2.3	Machine Description	12
2.4	Safety Devices	13
2.5	Technical Specification	15
2.6	Identification Data of the Machine	16

3 BEFORE OPERATING THE MACHINE

3.1	Shipping	17
3.2	Transportation & Unload Machine from Pallet	17
3.3	Operation Space	18
3.4	Operation Elements	19
3.5	Threading of Polypropylene Strap	20

4 OPERATING THE MACHINE.....	22
5 ADJUSTMENT.....	23
6 TROUBLE SHOOTING.....	25
7 MAINTENANCE.....	26
8 ELECTRIC WIRING DIAGRAM & PART.....	28
9 PART LIST.....	33

1. GENERAL SAFETY INSTRUCTIONS

1.1 Basic Operation

- The manual and the safety remarks are to be read before use. The operator manual should be kept with the machine at all times. Intervals for maintenance and inspections are to be adhered to.
- This machine was built with state of the art technology and rigid adherence to safety standards.
- Unless used properly, it can cause injury to operators or persons in close proximity to the machine. In addition, improper use can cause damage to the machine or property around the machine.

1.2 Basic Safety Precautions

- The user is to be instructed in all other generally applicable legal and other mandatory regulations relevant to accident prevention and environmental protection in addition to the operating instructions.
- For safety reasons, long hair must be tied back or otherwise secured, garments must be close fitting and no jewelry may be worn.



- Use protective equipment whenever required by circumstances or by law.
- Carefully observe all safety instructions and warnings attached to the machine and make sure that they are always complete and perfectly legible.
- Always make certain that persons being trained and instructed in working on or with the machine are permanently supervised by an experienced person.
- Work on the electrical system and equipment of the machine is only to be carried out by a skilled electrician or by persons under the supervision and guidance of a skilled electrician and in accordance with the rules and regulations of electrical engineering.

1.3 Safety Instructions Governing Specific Operational Phases

- Avoid any operation mode that might be unsafe.
- All necessary precautions to ensure that the machine is only used being in a safe and reliable state are to be taken. The machine is only to be operated if all protective and safety devices, including removable safety devices, emergency shut-off equipment, noise-protection elements and exhaust systems are in right place and fully functional.
- The machine is to be checked for damage and defects at least once per work shift. Any changes including the working behavior of the machine are to be reported to competent persons immediately. If necessary, the machine is to be stopped and locked immediately.
- In case of any malfunction the machine must be stopped and locked until the defect has been eliminated.
- Generally make sure that nobody is at risk before starting up the machine.
- All personnel that will be operating this machine should be thoroughly trained in all phases of operation and safety.
- Always tighten unscrewed connections after maintenance and repair.
- After completing maintenance and repair all safety devices removed for setting up or repairing the machine must be reinstalled and checked for functionality prior to putting the machine back into service.
- To minimize the environmental impact all consumables and replaced parts must be disposed of safely.
- Before starting the machine check that the accessories have been stowed away safely.
- Do not attempt any operation that may be a risk to the stability of the machine.

1.4 Warning of Electrical Dangers



- Immediately remove power to the machine in case of trouble in the electrical system.
- Replace a fuse with one with the same style and ratings; pay particular attention to matching the specified current.
- Any electrical work performed on the equipment must be conducted by a skilled electrician or under the supervision of a skilled electrician. All work must be observed good electrical engineering practice and follow safety rules and local wiring standards.
- Inspect the electrical equipment of the machine at regular intervals. Tighten any loose connections. Check wiring for scorch marks; replace scorched wiring and determine and correct the reason for the overheating.
- When working on live equipment, ensure that a second person is available to cut power in case of an emergency. When appropriate, secure the working area with safety tape and a warning sign. Use insulated tools for electrical work.
- Before working on high-voltage assemblies, turn off the power supply. Carefully discharge the supply cable and short-circuit any energy-storage components such as capacitors.
- If the equipment was moved, carefully refit and refasten all parts removed for transport before reapplying power.
- Before moving the machine, remember to disconnect the power cable.

1.5 Grounding Instructions Shall Include the Following

- This product must be grounded. In the event of an electrical short circuit, grounding reduces the risk of electric shock. This product is equipped with a cord that has a grounding wire and an appropriate grounding plug. The plug must be plugged into an outlet that is properly installed and grounded in accordance with all local codes and ordinances.
- If repair or replacement of the cord or plug is necessary, connect the ground wire to the ground terminal of the plug. The wire with green insulation (with or without yellow stripes) is the grounding wire.
- Check with a qualified electrician or service person if the grounding instructions are not clear or if in doubt about the proper grounding of the machine. Do not modify the plug provided; if it will not fit the power outlet, have the proper outlet installed by a qualified electrician.
- This product is designed for use on a nominal 230 volt AC circuit and has a grounding plug.

DANGER!

Improper installation of the grounding can result in electrocution.

1.6 Before Operating

- Verify that the power line voltage is correct.
- The machine must be properly grounded to avoid a shock hazard. All wiring must be in accordance with local wiring standards.
- The strapping machine can only be operated with polypropylene (P.P.) strapping; do not use polyester (PET) strapping or polyethylene (PE) cord strap.

1.7 During Operation







- The weight of the package cannot exceed 70kg. For package weight over 25kg, it may be necessary to use lifting aids for handling; while package weight over 40kg, it's necessary to handle it with conveyor system.
- The size of the package should not be less than 70 mm × 20 mm (2.75 inches × 0.75 inches).
- While running, check the unit for any unusual sounds or smoke emissions.
- Keep away from the inside of the arch while the machine is operating; do not you're your hands or body into the arch when the machine is running.

NOTE: It is normal for the heater tongue to smoke during the sealing operation.

1.8 After operating

- Remove dust and dirt from the unit
- Turn off the power when the machine is not in use.

1.9 Signs

	<p>Caution! Electric Shock Hazard.</p>
	<p>Caution! Hot Surface.</p>
	<p>Caution! Moving Parts Can Crush Hand.</p>
	<p>Caution! Pinch Point Entanglement</p>
	<p>Caution! Blade. Cutting of Fingers or Hand</p>
	<p>Wear Eye Protection</p>
	<p>Refer to Operator Manual</p>

2. MACHINE INFORMATION

2.1 Areas of Application

This plastic strapping machine can be used for a wide range of applications where the minimum package width is at least 60mm, and the minimum height is 20mm.

This machine is particularly suitable for heavy packaged goods as well as printed products, boxes, etc.

Packaging Limitation

It's not possible to pack:

- Products larger or heavier than that allowed.
- Wet Products
- Flammable products
- Explosive products
- Agri-foodstuffs
- Pharmaceuticals
- Hazardous products

2.2 Environmental Information

The strapping machine shall be installed in the following conditions:

- Supply voltage: +-10% nominal supply voltage
- Source frequency: +-10% nominal frequency
- Ambient temperature: 5°C - 40°C (41°F-104°F).
- Relative humidity: not exceed 35~85%RH
- Please provide a suitable illumination around the machine for safety operation.

Conditions For Use

Make sure there is room for easy application and maintenance

The machine must be installed in a closed, well-ventilated area where there are no

explosions or fire hazards Position the machine in a place free of humidity, flammable materials, gas or explosives. Make sure that it is level.

Please do not spray water or wet wipe machine body.

Noise - characteristic values

The noise emission values determined according to EN ISO 3746 for the sound power level or EN ISO 11202 for the sound pressure level at the workplace on the basis of the working conditions are as below:

A measurement uncertainty allowance of $K = 4 \text{ dB(A)}$ applies to the stated emission values.

Sound power level $L_{WA} = 88.7 \text{ dB(A)}$

Emission sound pressure level at the workplace $L_{PA} = 75.3 \text{ dB(A)}$

To minimize the emission sound pressure level, machine is equipped with a timer standby mode that can be adjusted by technician.

Demolition and Waste Disposal

The machine does not contain dangerous components or substances which require special disposal procedure. For that which concerns material elimination, comply with the Standards in the country where the machine has been disassembled.

Caution: do not leave waste polypropylene strap on the floor to minimize slip hazards.

2.3 Machine Description

- Semi-Automatic strapping machine for polypropylene (PP) strapping material.
- Strap width 5-15.5mm adjustable.
- High efficiency of heater plate.
- Extra strong construction.
- Simple and user-friendly operation.
- Electronic outside tension control.
- Strap tension adjustable from soft to very high.
- Simple and easy maintenance

2.4 Safety Devices

DANGER!

Operate the machine only when all safety devices are at their place and are functioning correctly.

The machine has been constructed in accordance with the applicable legal regulations.

The machine is reliable in operation. Nevertheless the machine may constitute a danger if it is operated in improper or undue condition.

Danger points that cannot be avoided due to equipment design are equipped with safety devices. If necessary, these points are marked on the machine with warning signs, and in the manual under working safety instructions.

The machine is equipped with safety devices as:

- Warning labels
- Live parts are covered
- Table cover with screw fixed (1)

Only Polypropylene strapping can be used in this machine. The use of other synthetic Straps can produce substances hazardous to health.



Caution!

The heating unit operates at a very high temperature in order to melt the P.P. strapping. To prevent burns, avoid contact with this area. (2)

To move the machine, the two lockable casters (3) must be unlocked. Relock the two casters when the machine is in its new position.

The machine is turned on when it is connected to AC power and the main power switch, located on the front operating panel, is placed in the ON position. After approximately 1 minute, the heating element will reach its operating temperature and the machine will be ready for use.

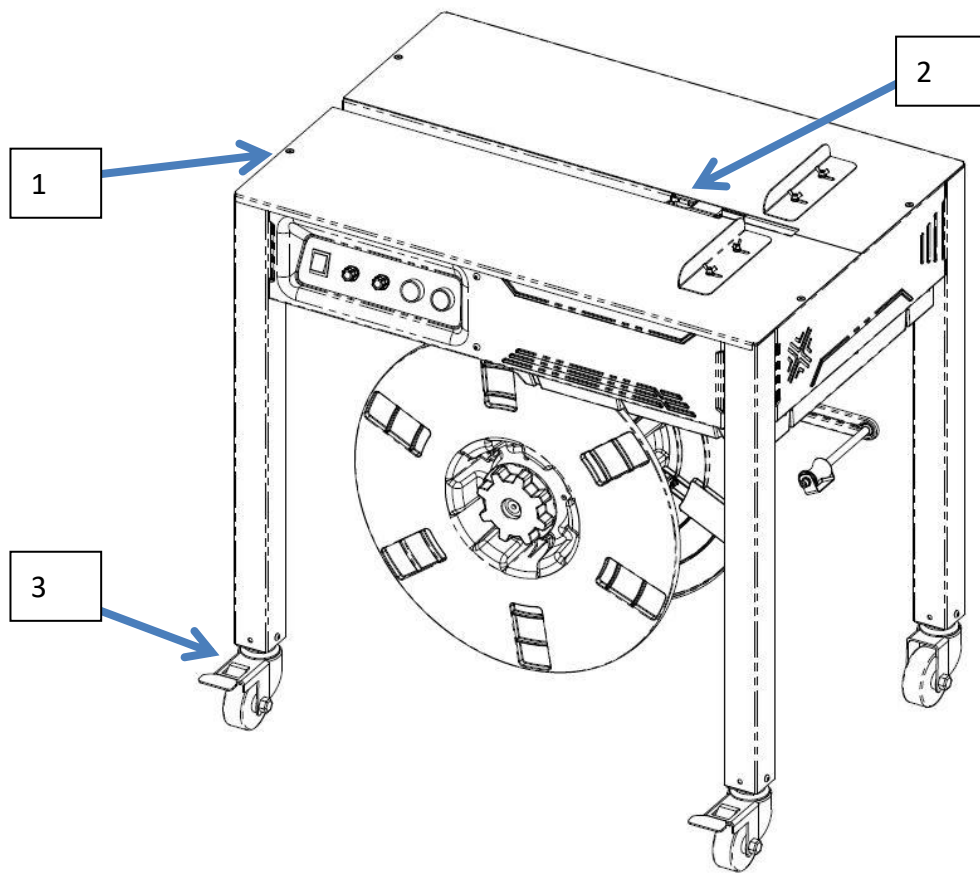

If it is necessary to make adjustments inside the machine during operation, after a strap jam for example, the table top can be unscrewed. Observe caution as the machine is still fully functional with the covers removed. If machine with safety switch, when table top is opened, safety switch is activated. This will remove power but heating element is keeping heating.



Caution!

2.5 Technical Specification

2.5.1 Electrical Specification

System Configuration	L1+N+PE (GROUND)	L1+N+PE (GROUND)
Nominal Power	0.2 kW	0.2 kW
Rated Current	0.8 A	1.6 A
Rated Voltage	200V/220V/230V/240V	100V/110V
Rated Frequency	50/60 Hz	60/60 Hz
Type of Current	AC- single phase	AC – single phase

2.5.2 Technical information

STRAP WIDTH	5-15.5mm ONLY ADJUSTMENT
STRAP THICKNESS	0.45mm – 0.7mm
STRAP COIL	Coil diameter: 200mm (230mm/280mm as option) Width: 190mm-200mm
MACHINE SIZE	784mm (L)* 546mm (W) * 780mm (H)
NET WEIGHT	46 Kg
TENSION RANGE	10 N – 500 N
SPEED	1 m/s for Feeding 1 m/s for Reversing
TABLE HEIGHT	780mm Adjustable table height as OPTION
NOISE EMISSION	75 dB
AMBIENT TEMP.	5°C - 40°C

2.6 Identification Data of the Machine

Each model is provided with a plate where it is easy to recover data which must be communicated to the manufacturer in case of problem or when requesting spare parts etc. (ref. 1-2-3-4) This plate also carries electrical technical data for installation of the machine. (ref. a-b-c-d-e-f-g).

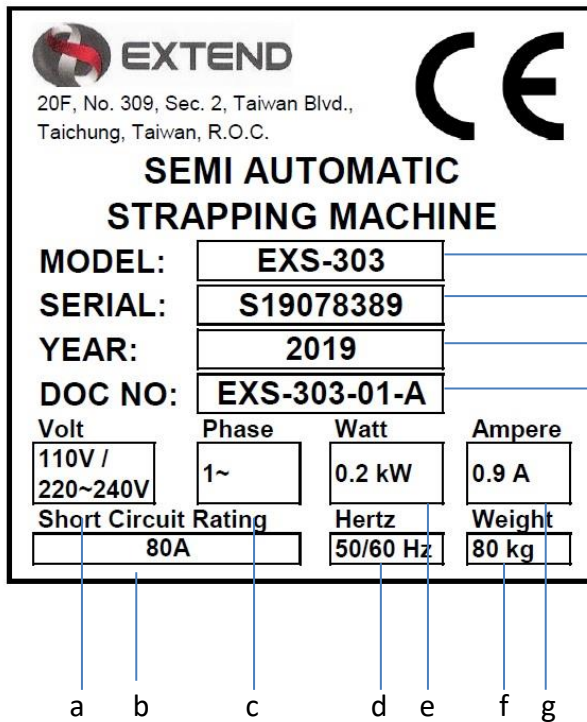

1. Model
 2. Serial Number
 3. Year of Manufacture
 4. Doc. Number
-
- a. Rated voltage (V)
 - b. Rated Current (A)
 - c. Frequency (Hz)
 - d. Short Circuit Rating (A)
 - e. Phase (PH)
 - f. Rated power (Watts)
 - g. Weight (kg)

3. BEFORE OPERATING THE MACHINE

3.1 Shipping

The machine is delivered as a transport unit. The machine is loaded onto a wooden pallet with Polyester strap secured. Outside with carbon box also with Polyester strap secured.

3.2 Transportation & Unload Machine from Pallet

The machine needs to be secured well on wooden pallet. The side edge of machine body needs to be sitting on the pallet to make sure casters are free (1). Remove protection material around the machine like stretch film and plastic cover, and then do remove the Polyester strap.

Please lift the machine on left & right side from the pallet.

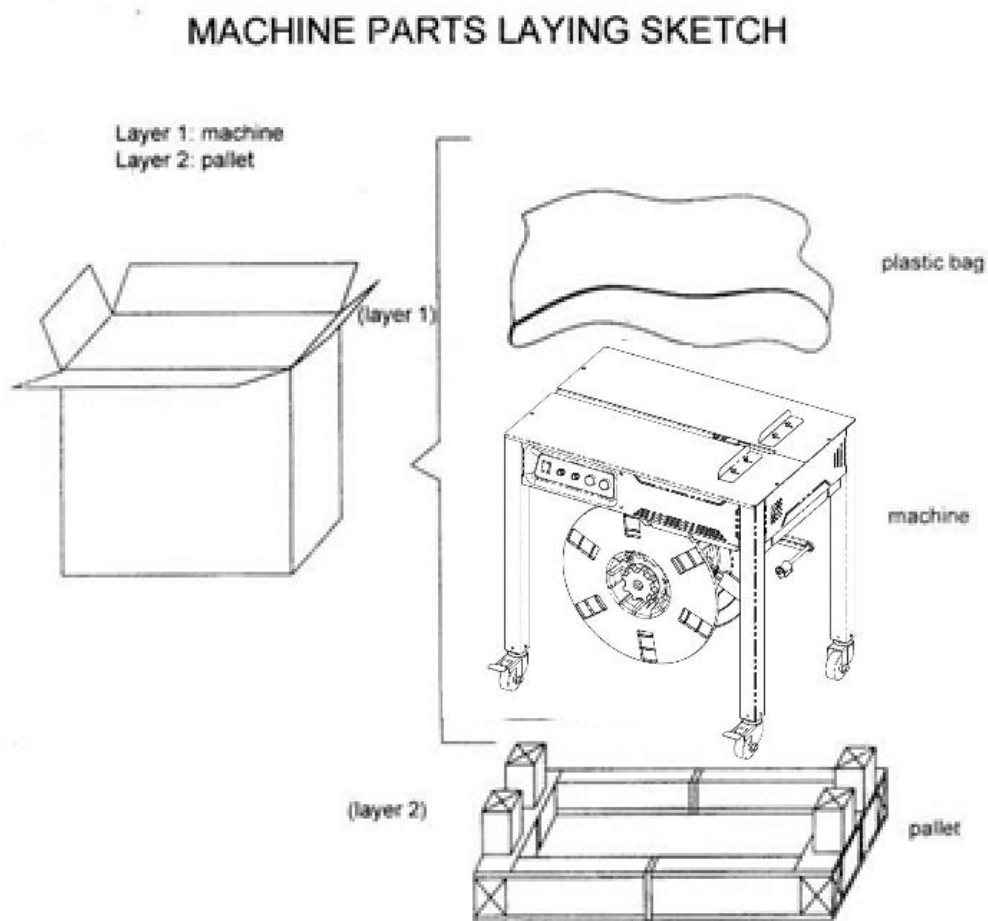

3.3 Operation Space

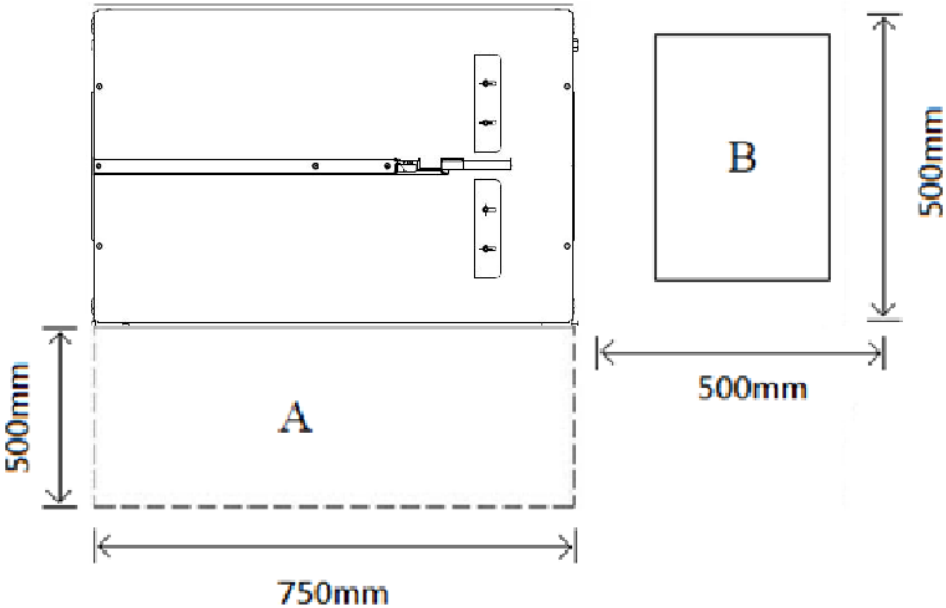

Keep the area (A) and (B) free for the operator.

The area (A) is necessary for operation strapping machine or changing the strap coil.

3.4 Operation Elements

➤ Power switch

To turn ON/OFF power of machine

➤ Tension adjust VR

This adjust VR is to control tension force (secondary tension). Rotate clockwise to increase tension and counter clockwise to decrease tension.

➤ Feed length adjust VR

This adjust VR is to control feeding length for next strap. Rotate clockwise to increase feeding length and counter clockwise to decrease feeding length.

➤ Manual feed button

This button is to manual feed strap outward.

➤ Reset button

This button is to reset current cycle to go back to ready position.

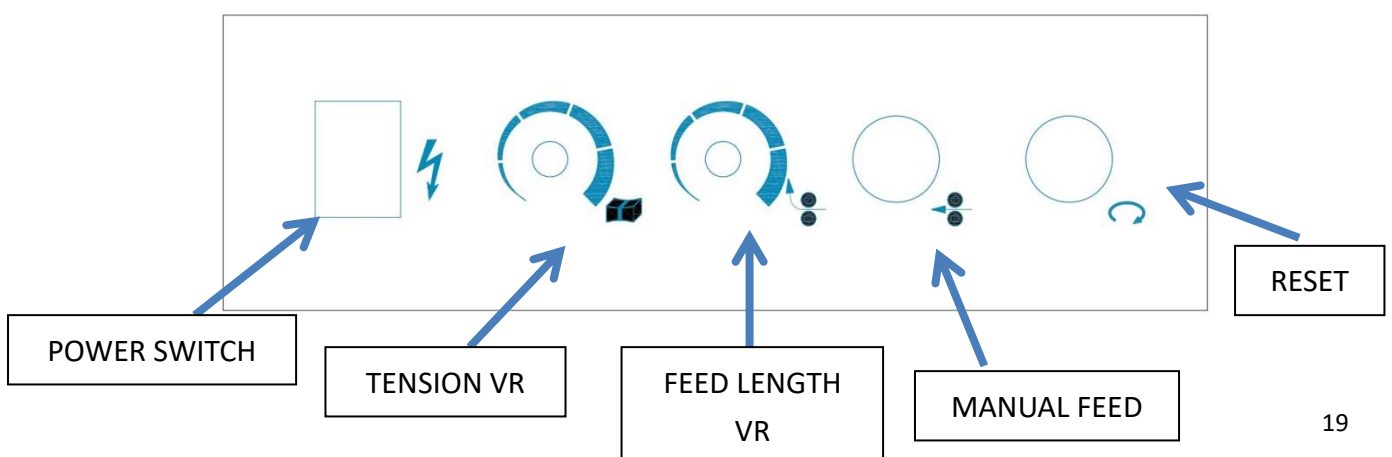
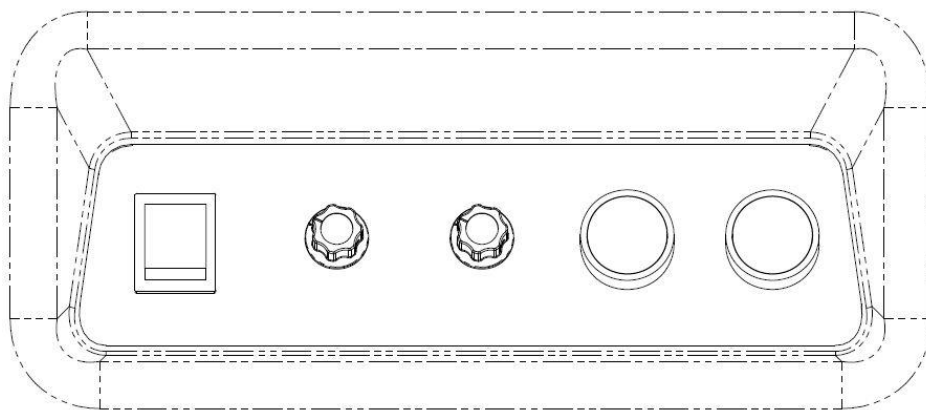

3.5 Threading of Polypropylene Strap

3.5.1 Strap Specification

Material: Polypropylene Strap

Width: 5-15.5mm only adjustment

Thickness: 0.45mm-0.7mm (any strap outside this range, please contact EXTEND for further studying)

Core diameter: 200mm (230mm and 280mm as option)

Core width: 190mm-200mm

Strap with excessive chamber (5mm with 200cm length) cannot be used.

3.5.2 Strap Coil Installation

How to Load and Thread P.P. Strap

The threading procedure involves routing strap from the dispenser and up through the strapping head.

- a. Rotate nut handle (A) counter clockwise to remove from dispenser unit, take off the dispenser flange and remove old strap coil inside.
- b. Remove all adhesive strips or other adhesive material from new strap coil
- c. Follow the rotation direction sticker on dispenser, to put the new strap coil onto dispenser unit
- d. Put the outer dispenser flange back on and tighten reel nut handle (A) in clockwise.
- e. Unroll about 0.5 m of strap and make sure that it is not twisted.
- f. Thread the strap through the guide roller bracket (B) and the loop (C).
- g. Insert strap upward into machine, until the strap hits something, then please hold the strap
- h. Press the feed button to feed the strap.

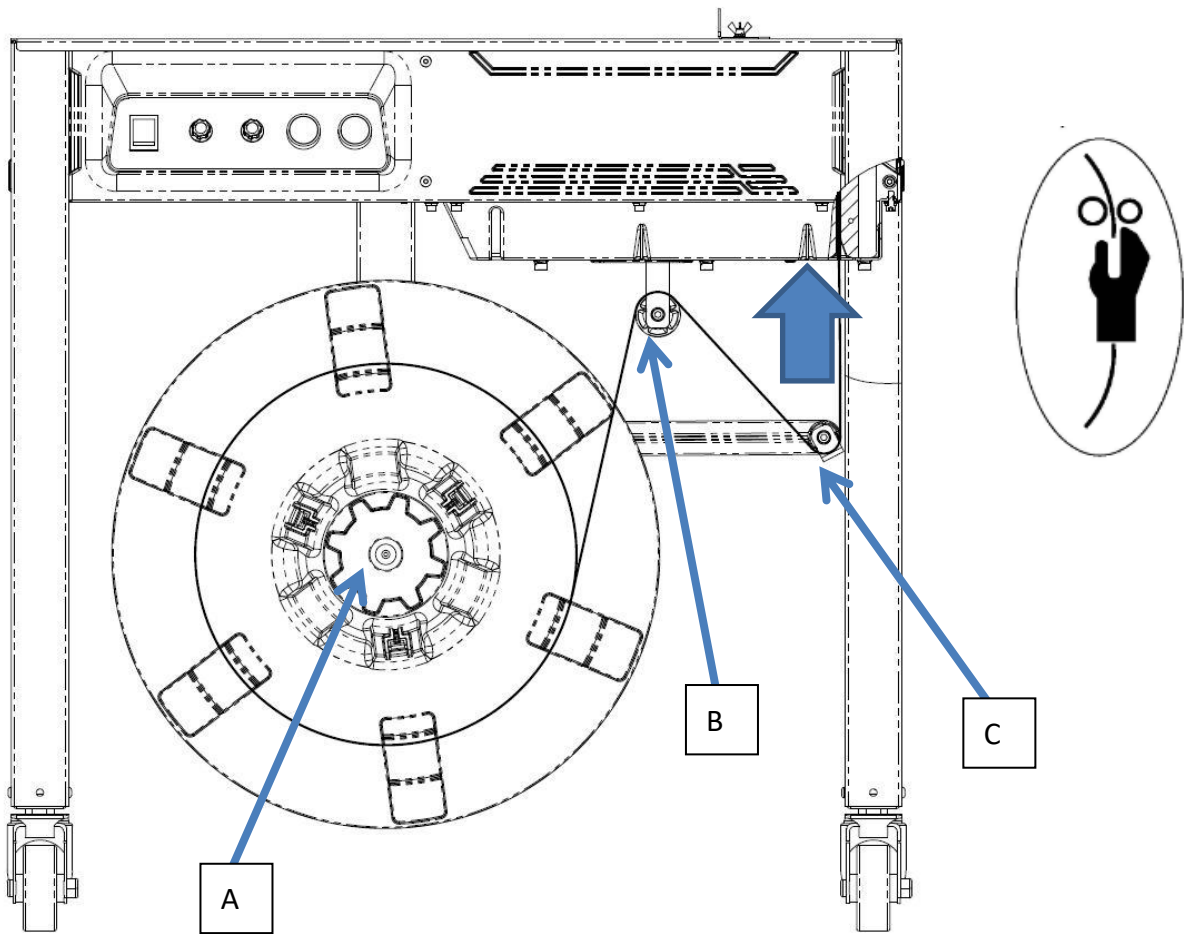

Noted: Please make sure PP strap is in correct curve down direction, to have the PP strap insert into machine in opposite direction, it might cause auto threading, feed, refeed...functions not stable.

4. OPERATING THE MACHINE

- a. Turn main switch QS1 to ON. The heating element reaches the working temperature at approximately 1 minute.
- b. Place a package on the table top (The package must cover the Slide Table).
- c. Properly adjust the strap tension knob according to various packages.
- d. Place the strap around the package to be strapped and insert the strap into the trapping head to activate micro-switch until strapping cycle stops.
- e. The strapping and welding sequence should complete.
- f. At end of strapping sequence the strap end is fed automatically, and Feed length adjustment knob is to adjust the strap length
- g. Adjustment

➤ JOG:

This JOG function is for service only, it could make machine go step by step. In any position, you could press RESET button back to ready position

➤ COOLING TIME:

Cooling time is for big tension strap on hard package to have longer cooling time after strap is hot sealed.

➤ TEMP.

This adjust VR is for heater plate temperature. Depend on PP strap or working environment, you might need to adjust this heater plate temperature for better sealing on straps. The default setting will be around 290 Celsius degree for polypropylene straps.

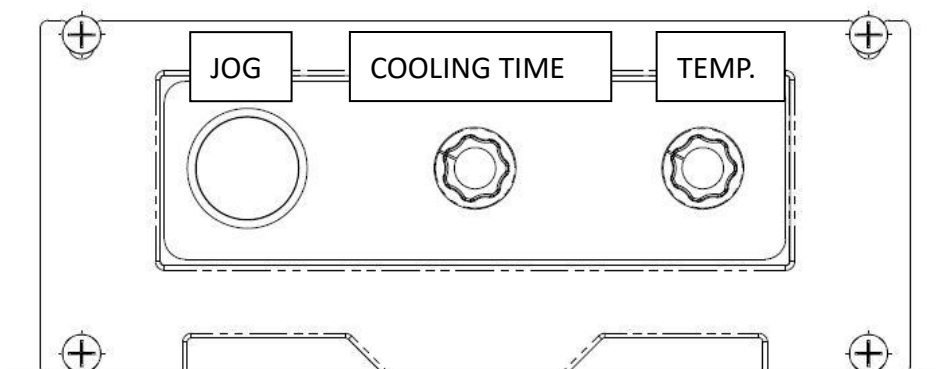

5. ADJUSTMENT

Change Strap Width

The machine is able to change between 5mm and 15.5mm strap only adjustment.

Noted: Tool Needed

- a. With three marking as 5mm/9mm/12mm, for 15.5mm just pull out the adjust plate to the end. Please follow the marking on the adjust plate then pull out 1mm more and then tight screw to fix the adjustment.

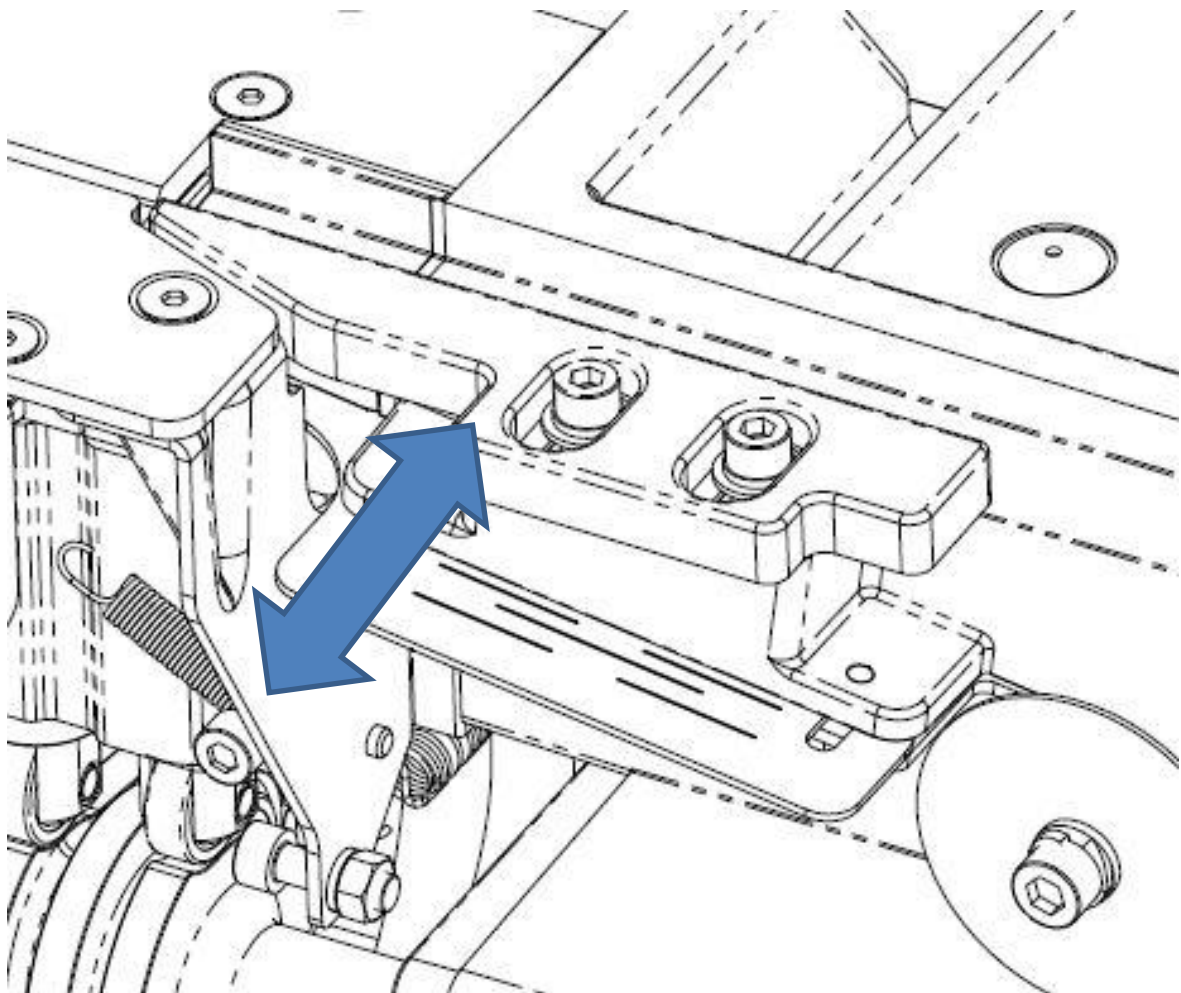

- b. Adjust this guide with strap width with 1mm more, and then tight screw to fix the adjustment

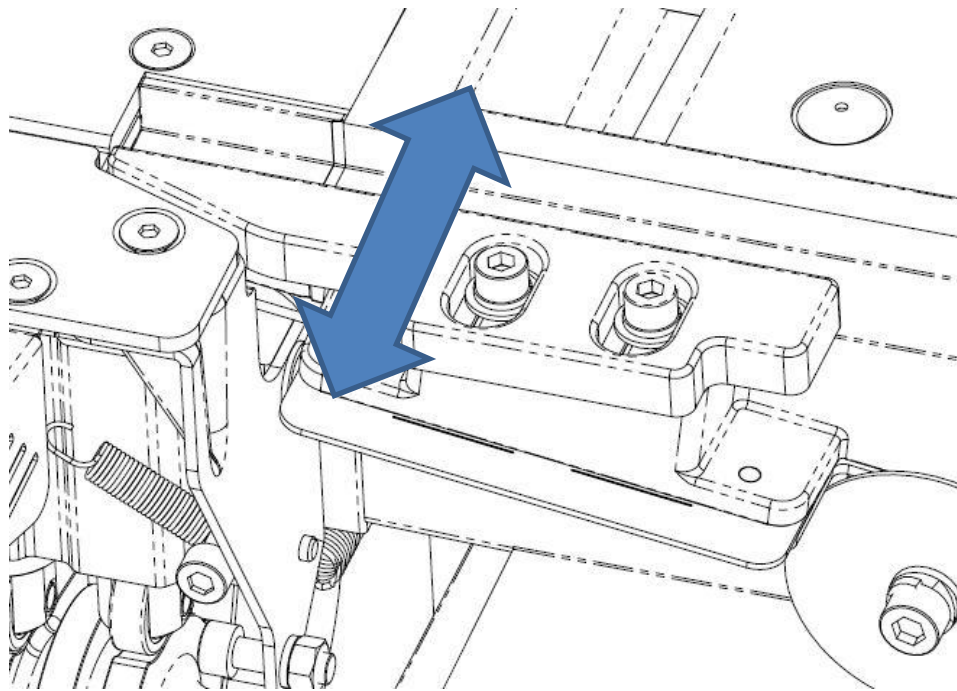

- c. Adjust this guide with strap width with 1mm more, and then tight screw to fix the adjustment

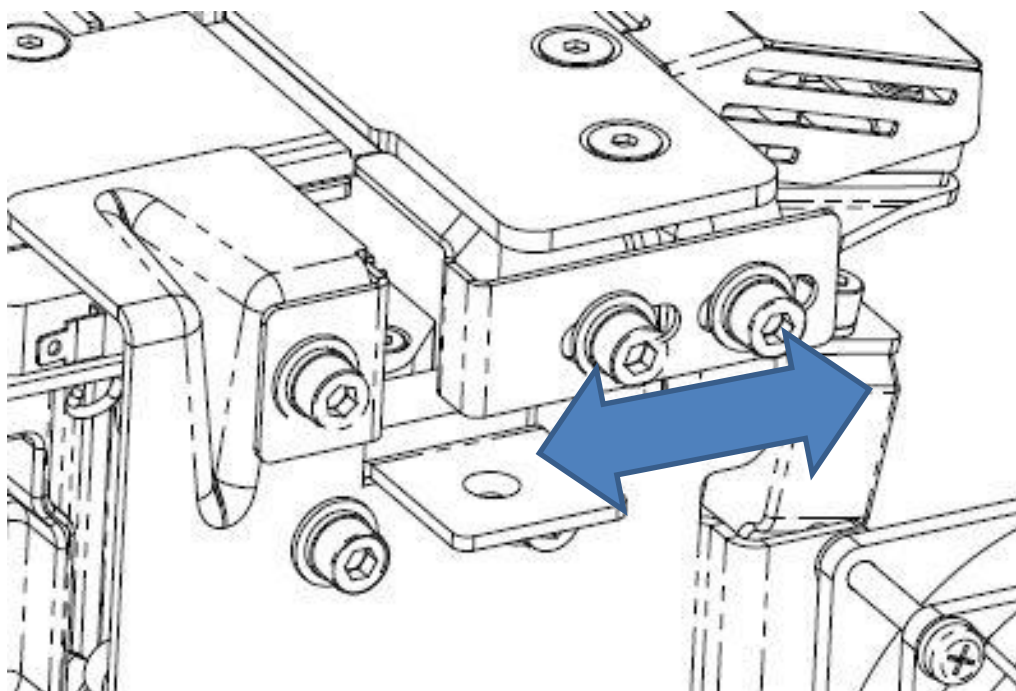

6. TROUBLE SHOOTING

➤ **Feeding or Reversing is not smooth**

Please check strap width adjustment is correct, please check **operation manual 5. ADJUSTMENT.**

➤ **Sealing is not good**

- Please adjust Temperature VR for higher temperature setting.
- Please adjust Cooling Time VR for longer cooling time setting
- Please use JOG to check if heater plate's movement is smooth

➤ **Machine cannot feed**

Please press RESET button to make sure this machine is in ready position.

➤ **Machine does not function when strap insert to the chute**

Please check the actuator if working correctly, to adjust the actuator position or to replace.

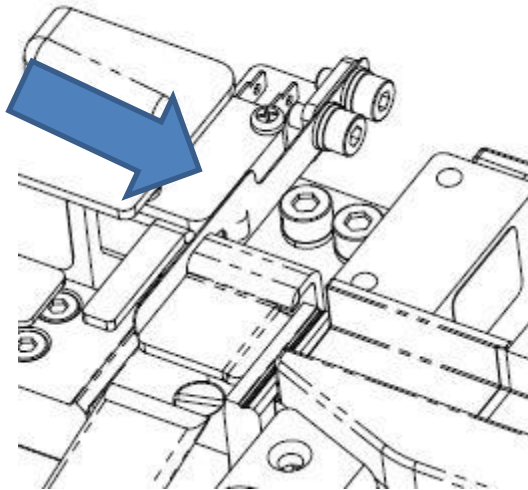

7. MAINTENANCE

Noted: Before doing any maintenance or service, please do switch off the main power on the machine, then wait about 5 minutes to cool down the heater plate.

Weekly Maintenance:

- Use air gun to clean dust from the machine, especially following clean dust from following structures:

- Strap guiding

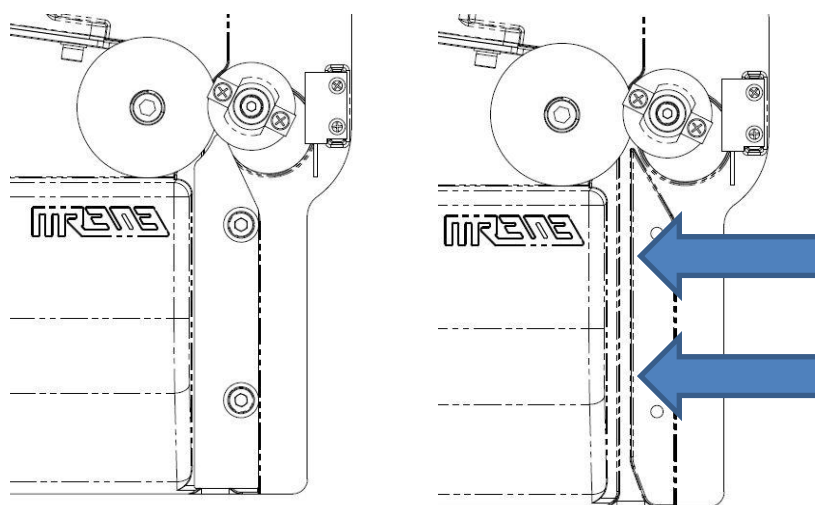

- Clamps Unit

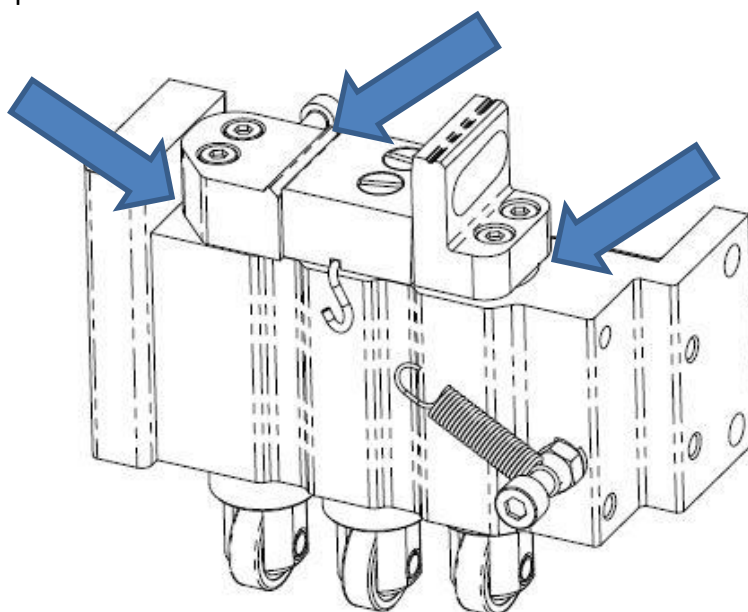

- Lubrication on moving mechanism , especially lubricate on following structures:
 - Clamps Unit (Between clamp seat and clamps)

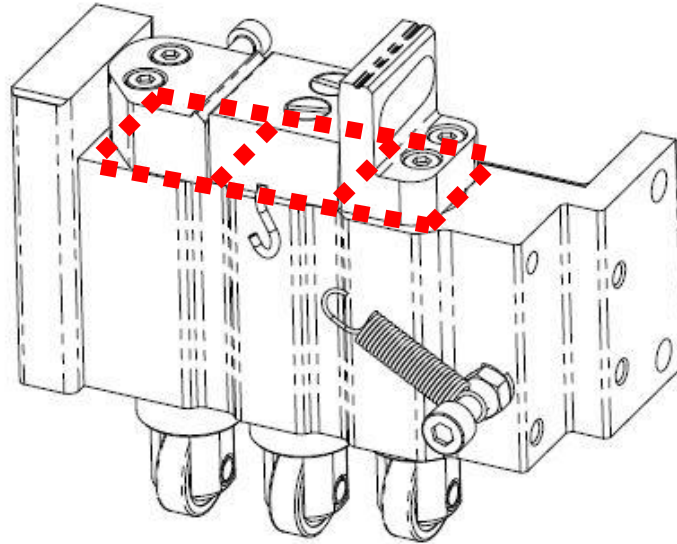

Noted: Do not lubricate on any bandway or guide where transport strap.

Noted: After cleaning and lubrication, please do several bundles to check.

Monthly Maintenance:

- Please take out END GRIPPER UNIT and WELDING CLAMP UNIT to do complete cleaning and lubrication
- Please clean both sides (upper/lower) of Heater Plate
- Please check all structure with spring if working smoothly
- Please clean dust around limit switch
- Please clean dust accumulated on rollers (Pool Feed Roller, Tension Roller, Feed Roller)

8. ELECTRIC WIRING DIAGRAM & PART

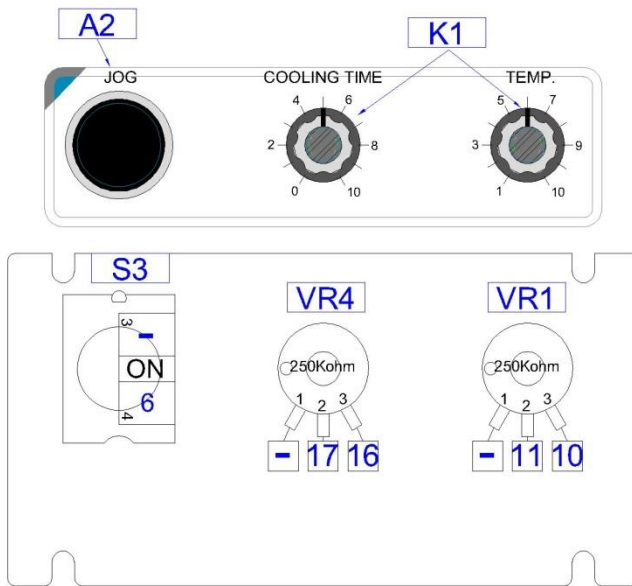

KEY NO	PART NO.	DESCRIPTION	Q'TY
Q1	P0311-010000300	POWER SWITCH	1
F1,F2	P0305-030001100	FUSE, 8A-6*30mm	2
	P0305-020001000	FUSE SEAT	2
	P0305-020001100	FUSE CAP	2
F3	P0305-030000100	FUSE, 2A-6*30mm,	1
	P0305-020001000	FUSE SEAT	1
	P0305-020001100	FUSE CAP	1
F4	P0305-030000200	FUSE, 3A-6*30mm	1
	P0305-020001000	FUSE SEAT	1
	P0305-020001100	FUSE CAP	1
S2,S3	P0313-010006800	BUTTON (BLACK)	2
S1	P0313-010007300	BUTTON (BLUE)	1
P1	P0309-01001300A	MAIN PCB	1
P2	P0315-020000900	DC DRIVE CARD	1
VR1,VR2 VR3,VR4	P0318-010001700	POTENTIOMETER ADJUSTABLE	4
K1	P1113-0001000	KNOB RN-99F, \$ 6.4	4
T1	P0307-010001600	POWER SUPPLY	1
A1	P1002-0008600	OPERATION STICKER	1
A2	P1002-0008700	PANEL STICKER	1
X1	P0304-010001200	TERMINAL SEAT	1

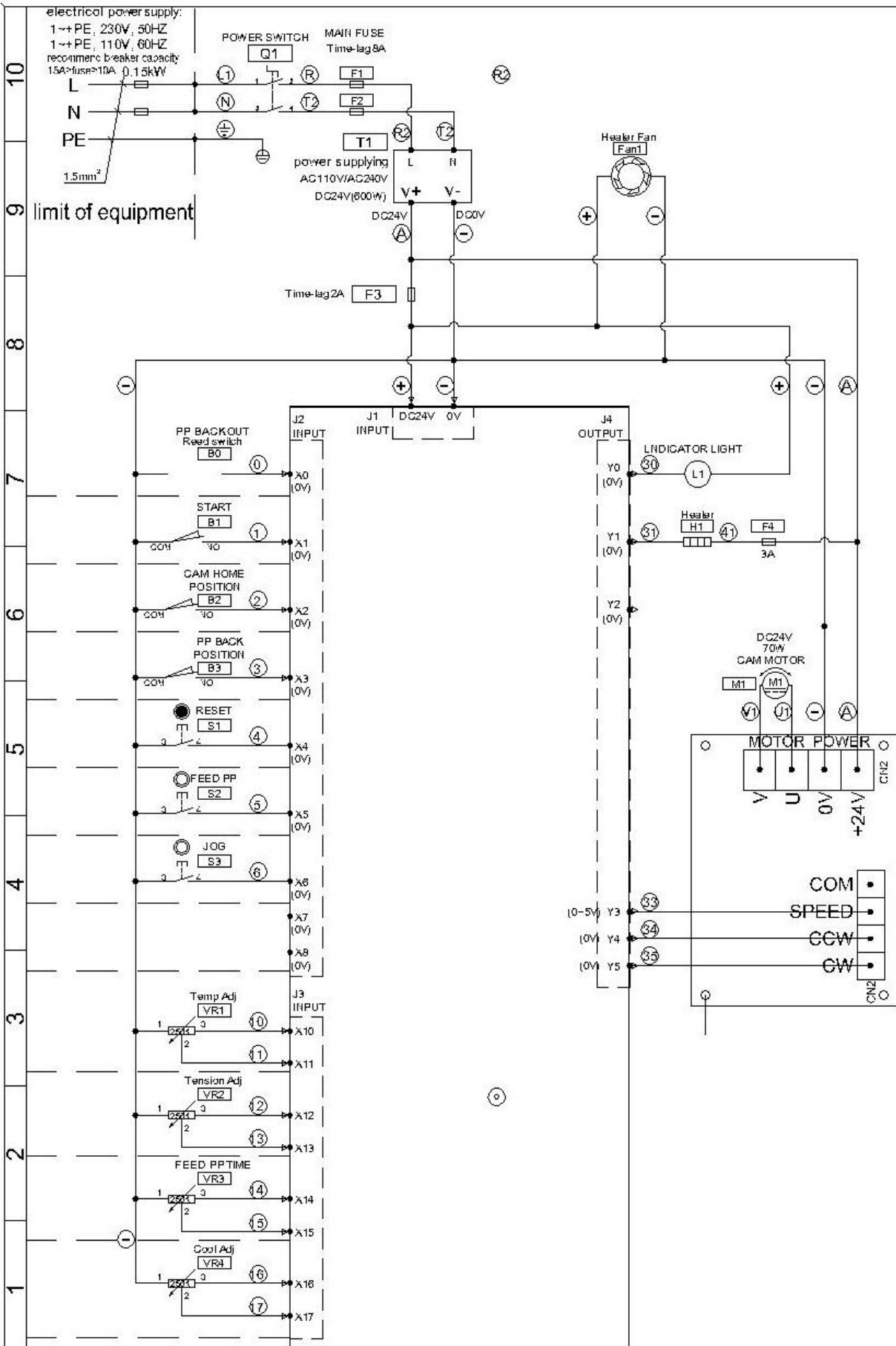

10
9
8
7
6
5
4
3
2
1

9. PART LIST

FIG. 1-1 SEALER SEAT UNIT

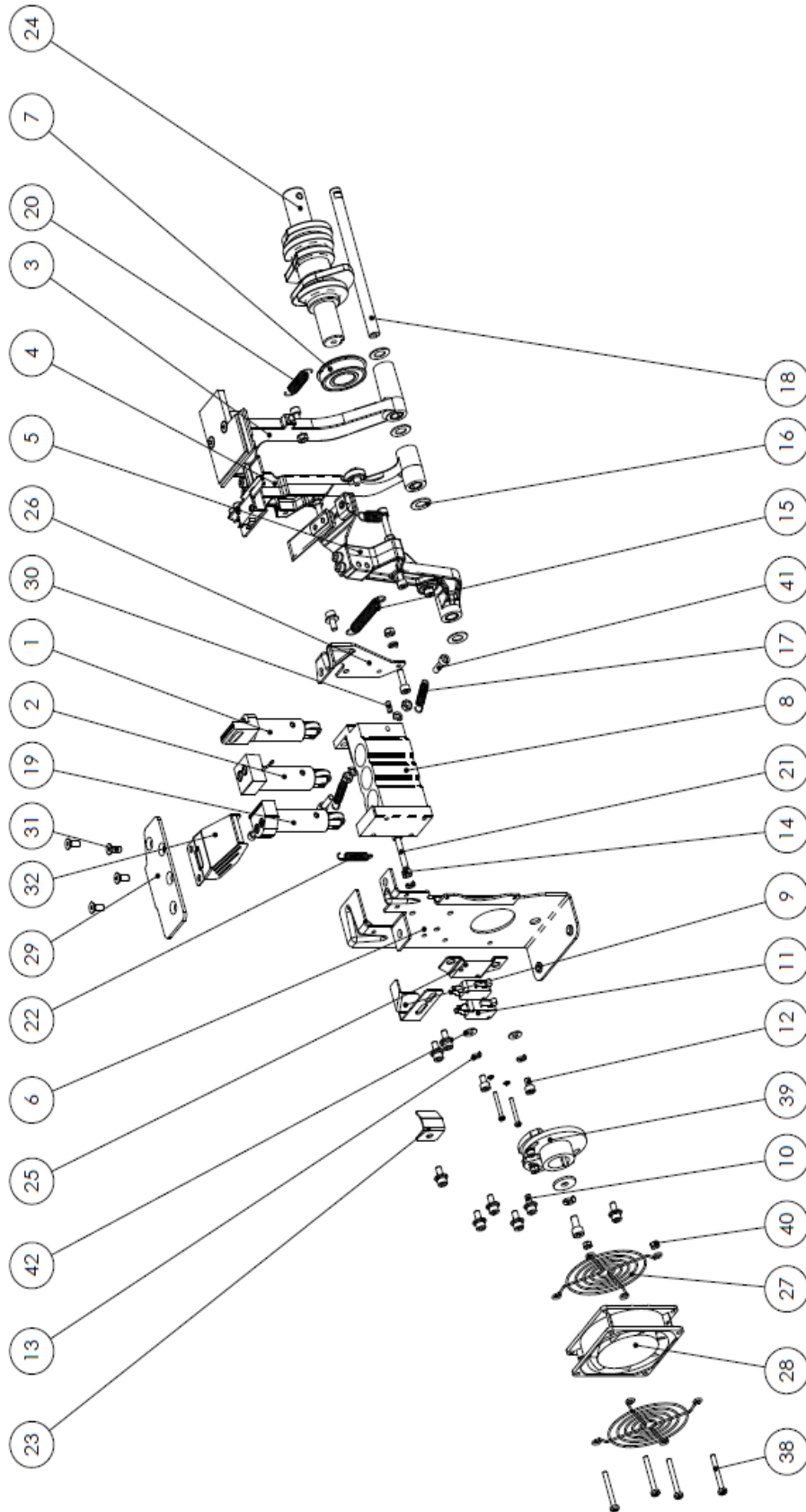

FIGURE 1-1 SEALER SEAT UNIT			
NO.	PART NUMBER	DESCRIPTION	QTY
1	P02-0362100	END GRIPPER UNIT	1
2	P02-0362200	WELDING CLAMP UNIT	1
3		SLIDING TABLE UNIT	1
4		SEPETATOR UNIT	1
5		HEATER PLATE UNIT	1
6	P01-0575800	SEALER SIDE PLATE	1
7	P1104-076004ZZ1	BEARING 6004ZZ-NR(CWB)	1
8	P02-0357900	CLAMP SEAT	1
9	P01-057650A	EXIT ADJUST PLATE	1
10	P1101-0905012AN	SCREW M5x12	10
11	P0311-060001600	MICROSWITCH MQS-216	2
12	P1101-0505008AN	SCREW M5x8	2
13	P1103-0205Z	SPRING WASHER ϕ 5	6
14	P1102-0105AN	NUT M5	4
15	P1202-0011500	SEPARATOR ARM SPRING	1
16	P06-0066400	ARM SPACER	4
17	P1202-0011900	WELDING CLAMP SPRING	2
18	P02-0357300	ARM SHAFT	1
19		HOLDING GRIPPER UNIT	1
20	P1202-0011600	SLIDING TABLE SPRING	1
21	P1101-0505030AN	SCREW M5*30	1
22	P1202-0011800	HOLDING GRIPPER SPRING	1
23	P01-0576400	EXIT BASE PLATE	1
24	P02-035910B	CAM UNIT	1
25	P01-0576800	MICROSWITCH BRACKET	1
26	P01-0576200	COVER SUPPORT	1
27	P0303-020000100	FAN NET FG-08	2
28	P0319-S30304	FAN DC24V	1
29	P01-0576300	SLIDING TABLE HOLDER	1
30	P1109-0205010G	PIN 4*10	1
31	P1101-0405012AN	SCREW M5x12	4
32	P01-0584000	HEATER PLATE COVER	1

FIGURE 1-1 SEALER SEAT UNIT			
NO.	PART NUMBER	DESCRIPTION	QTY
33	P1101-0303025AZ	SCREW M3x25	2
34	P1103-0203Z	SPRING WASHER ϕ 3	2
35	P1101-0506012AN	SCREW M6x12L	1
36	P1103-01062102Z	WASHER M6x21x2t	1
37	P1103-0206Z	SPRING WASHER ϕ 6	1
38	P1101-0304035AZ	SCREW M4x35L	4
39		POSITION CAM UNIT	1
40	P1102-0104AN	NUT M4	2
41	P1101-0505016AN	SCREW M5x16	3
42	P1103-01051201Z	WASHER M5x12x1t	2

FIG. 2-1 FEED DRIVE UNIT

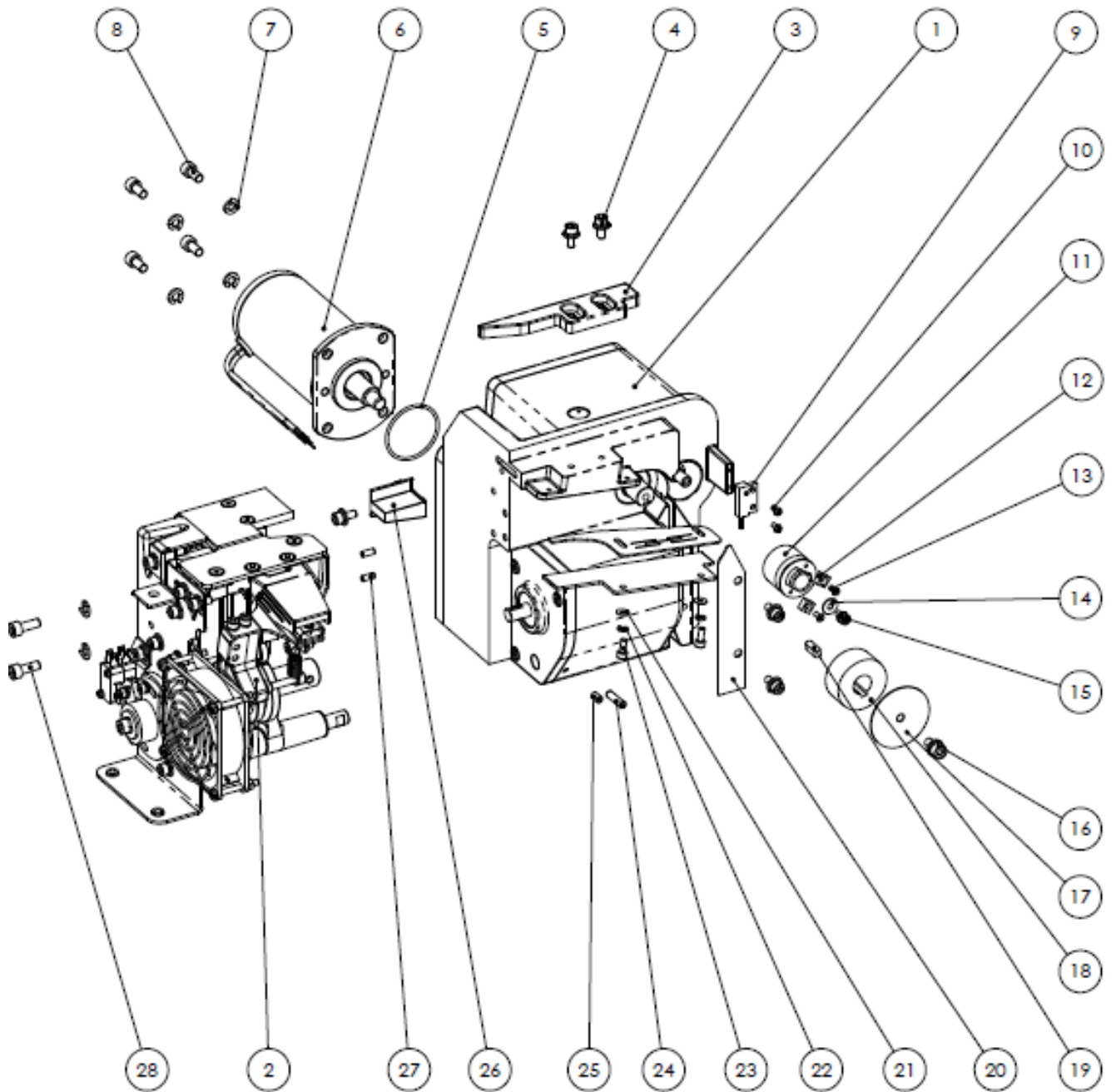

FIGURE 2-1 FEED DRIVE UNIT			
NO.	PART NUMBER	DESCRIPTION	QTY
1	P02-0363000	GEAR REDUCER	1
2		SEALER SEAT UNIT	1
3	P06-0066600	ADJUSTA PLATE - TOP	1
4	P1101-0905012AN	SCREW M5x12	5
5	P1116-P0400	O RING	1
6	P0501-0019000	DRIVE MOTOR	1
7	P1103-0206Z	WASHER $\phi 6$	6
8	P1101-0506012AN	SCREW M6x12	4
9	P0319-S30303	MAGNETIC REED SWITCH LS-3	1
10	P1101-0303006AZ	SCREW M3x6	2
11	P02-0362500	DRIVEN ROLLER UNIT	1
12	P1106-020000200	MAGNET	2
13	P1101-0203008AZ	SCREW M3X8	2
14	P1103-010412N	WASHER $\phi 4$	1
15	P1101-0904008AN	SCREW M4x8	1
16	P1101-0906012AN	SCREW M6x12	1
17	P01-0577300	ROLLER PLATE	1
18	P02-0357700	DRIVING ROLLER	1
19	P1108-010505016G	KEY 5*5*16	1
20	P01-0577100	GUIDE COVER	1
21	P1103-010409N	WASHER $\phi 4$	2
22	P1103-0204Z	SPRING WASHER $\phi 4$	2
23	P1101-0504010AN	SCREW M4x10	2
24	P1109-0105020B	PIN 5*20	1
25	P1101-0705008AB	SCREW M5x8L	1
26	P06-0066500	STRAP GUIDE	1
27	P1109-0205010G	PIN 4*10	2
28	P1101-0506016AN	SCREW M6x16	2

FIG. 3-1 END GRIPPER UNIT

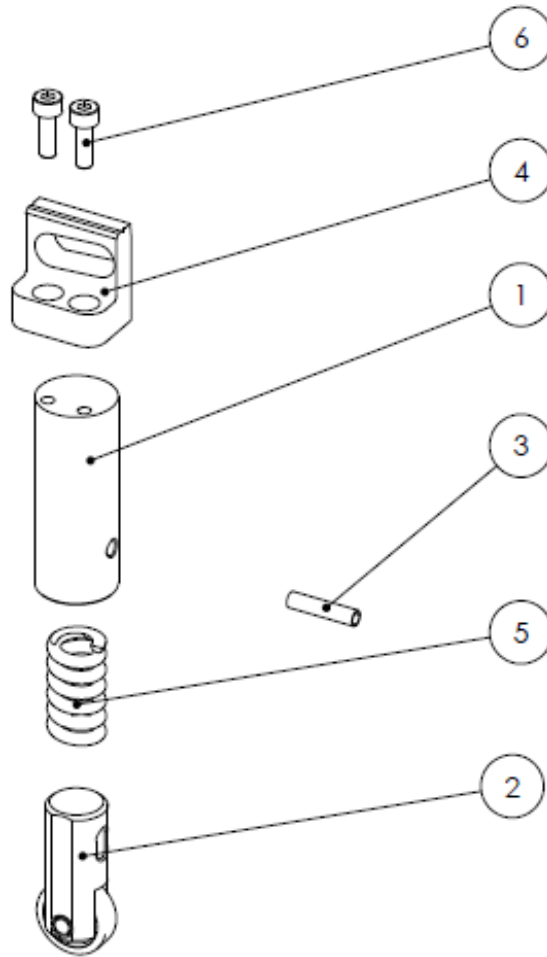

FIGURE 3-1 END GRIPPER UNIT			
NO.	PART NUMBER	DESCRIPTION	QTY
1	P02-035680A	CLAMP SEAT - SHORT	1
2	P02-0362900	CAM FOLLOWER UNIT	1
3	P1109-0104018B	PIN 4*18	1
4	P02-0357100	END GRIPPER	1
5	P1201-0010200	COMPRESS SPRING	1
6	P1101-0504012AN	SCREW M4x12	2

FIG. 4-1 WELDING CLAMP UNIT

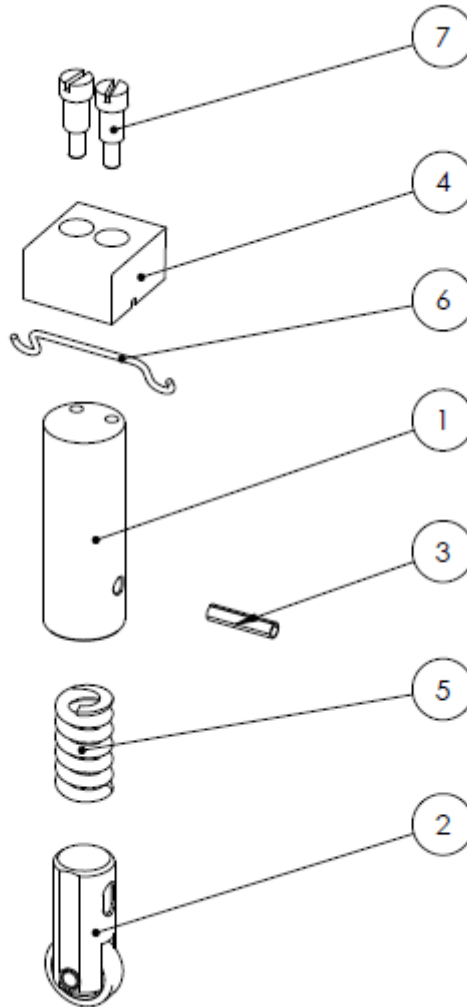

FIGURE 4-1 WELDING CLAMP UNIT			
NO.	PART NUMBER	DESCRIPTION	QTY
1	P02-035700A	CLAMP SEAT - LONG	1
2	P02-0362900	CAM FOLLOWER UNIT	1
3	P1109-0104018B	PIN 4x18	1
4	P02-035720A	CUTTER	1
5	P1201-0010200	COMPRESS SPRING	1
6	-	SPRING HOLDER – INCLUDED WITH CUTTER	1
7	P02-0358600	SHOULDER SCREW	2

FIG. 5-1 HOLDING GRIPPER UNIT

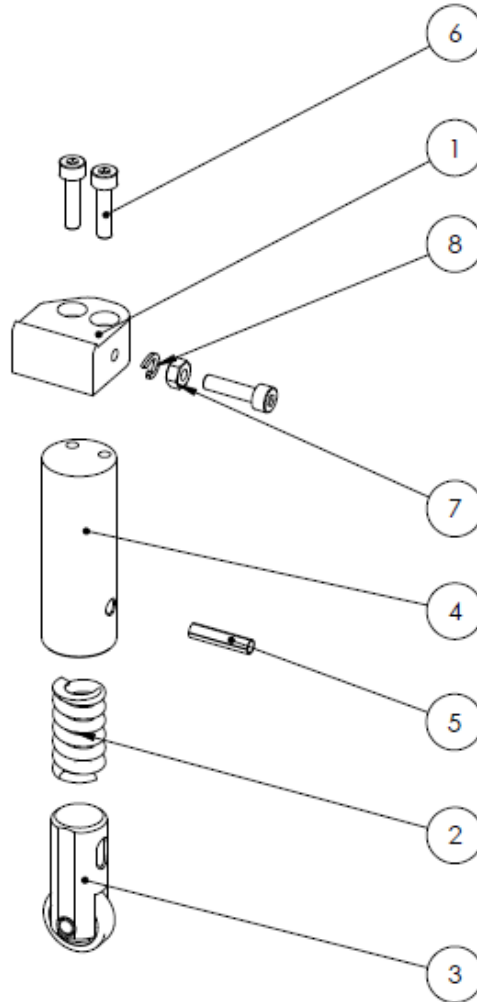

FIGURE 5-1 HOLDING GRIPPER UNIT			
NO.	PART NUMBER	DESCRIPTION	QTY
1	P02-0358000	HOLDING GRIPPER	1
2	P1201-0010200	COMPRESS SPRING	1
3	P02-0362900	CAM FOLLOWER UNIT	1
4	P02-035700A	CLAMP SEAT - LONG	1
5	P1109-0104018B	PIN 4X18	1
6	P1101-0504016AN	SCREW M4*16	3
7	P1102-0104AN	NUT M4	1
8	P1103-0204Z	SPRING WASHER φ4	1

FIG. 6-1 POSITION CAM UNIT

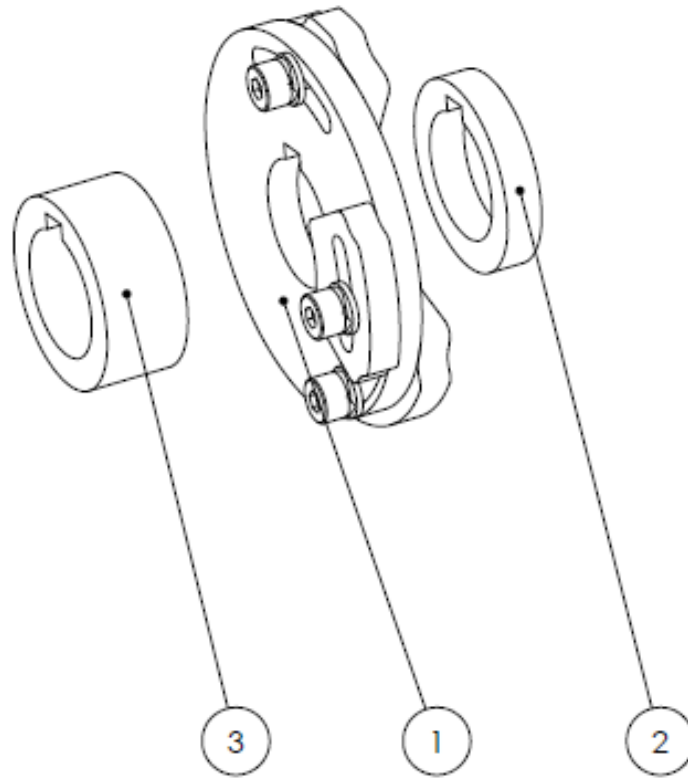

FIGURE 6-1 POSITION CAM UNIT			
NO.	PART NUMBER	DESCRIPTION	QTY
1	P02-0362600	POSITION CAM	1
2	P02-0360500	SPACER RING SHORT	1
3	P02-0360400	SPACER RING LONG	1

FIG. 7-1 SLIDING TABLE UNIT

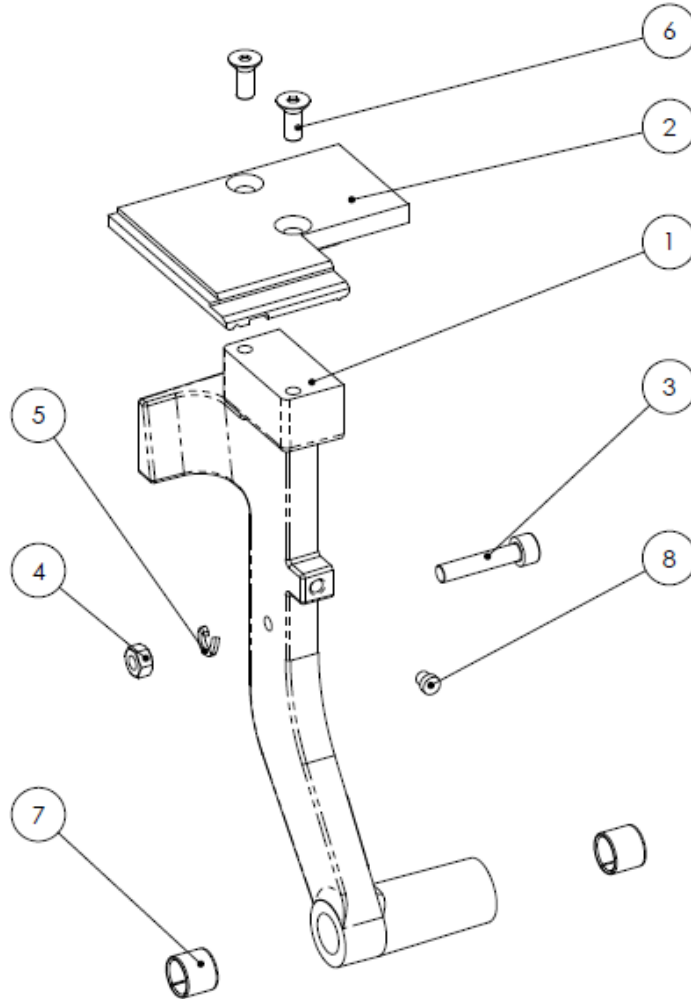

FIGURE 7-1 SLIDING TABLE UNIT			
NO.	PART NUMBER	DESCRIPTION	QTY
1	P02-0357500	SLIDING TABLE ARM	1
2	P02-0357400	SLIDING TABLE	1
3	P1101-0505025AN	SCREW M5X25	1
4	P1102-0105AN	NUT M5	1
5	P1103-0205Z	SPRING WASHER $\phi 5$	1
6	P1101-0405012AN	SCREW M5X12	2
7	P1104-0310101	BEARING CB1010	2
8	P06-0065300	CUSHION SPACER	1

FIG. 8-1 SEPARATING PLATE UNIT

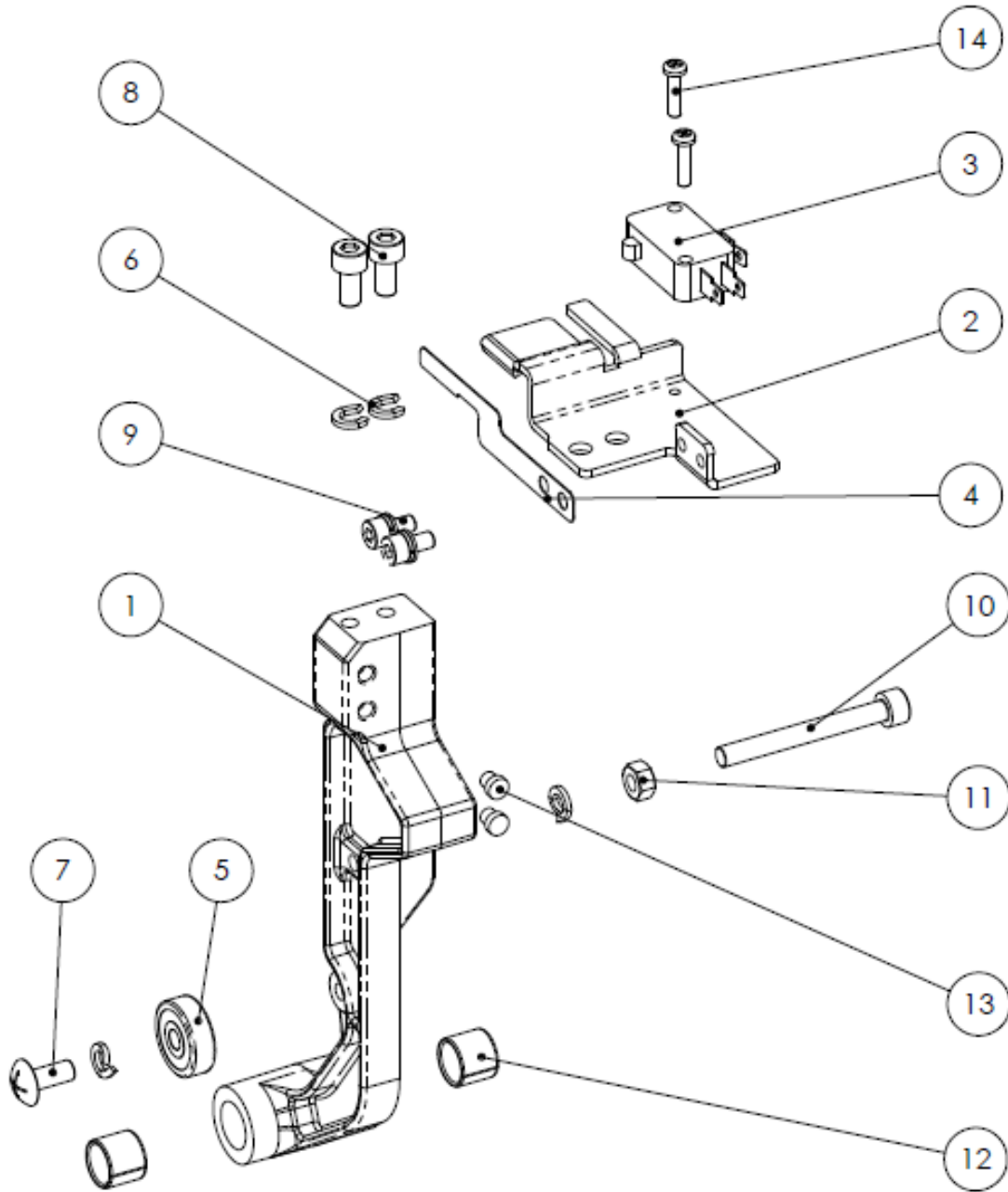

FIGURE 8-1 SEPARATING PLATE UNIT			
NO.	PART NUMBER	DESCRIPTION	QTY
1	P02-0357600	SEPARATOR ARM	1
2	P01-057560B	SEPARATOR PLATE	1
3	P0311-060000200	MICROSWITCH VX-5-1A2	1
4	P01-0575700	ACTUATOR	1
5	P1104-020635ZZ2	BALL BEARING 635ZZ	1
6	P1103-0205Z	SPRING WASHER ϕ 5	4
7	P1101-0105012AZ	SCREW M5*12	1
8	P1101-0505010AN	SCREW M5x10	2
9	P1101-0904008AN	SCREW M4x8	2
10	P1101-0505045AN	SCREW M5*45	1
11	P1102-0105AN	NUT M5	1
12	P1104-0310101	BUSHING CB1010	2
13	P06-0065300	CUSHION SPACER	2
14	P1101-0303012AZ	SCREW M3*12	2

FIG. 9-1 HEATER PLATE UNIT

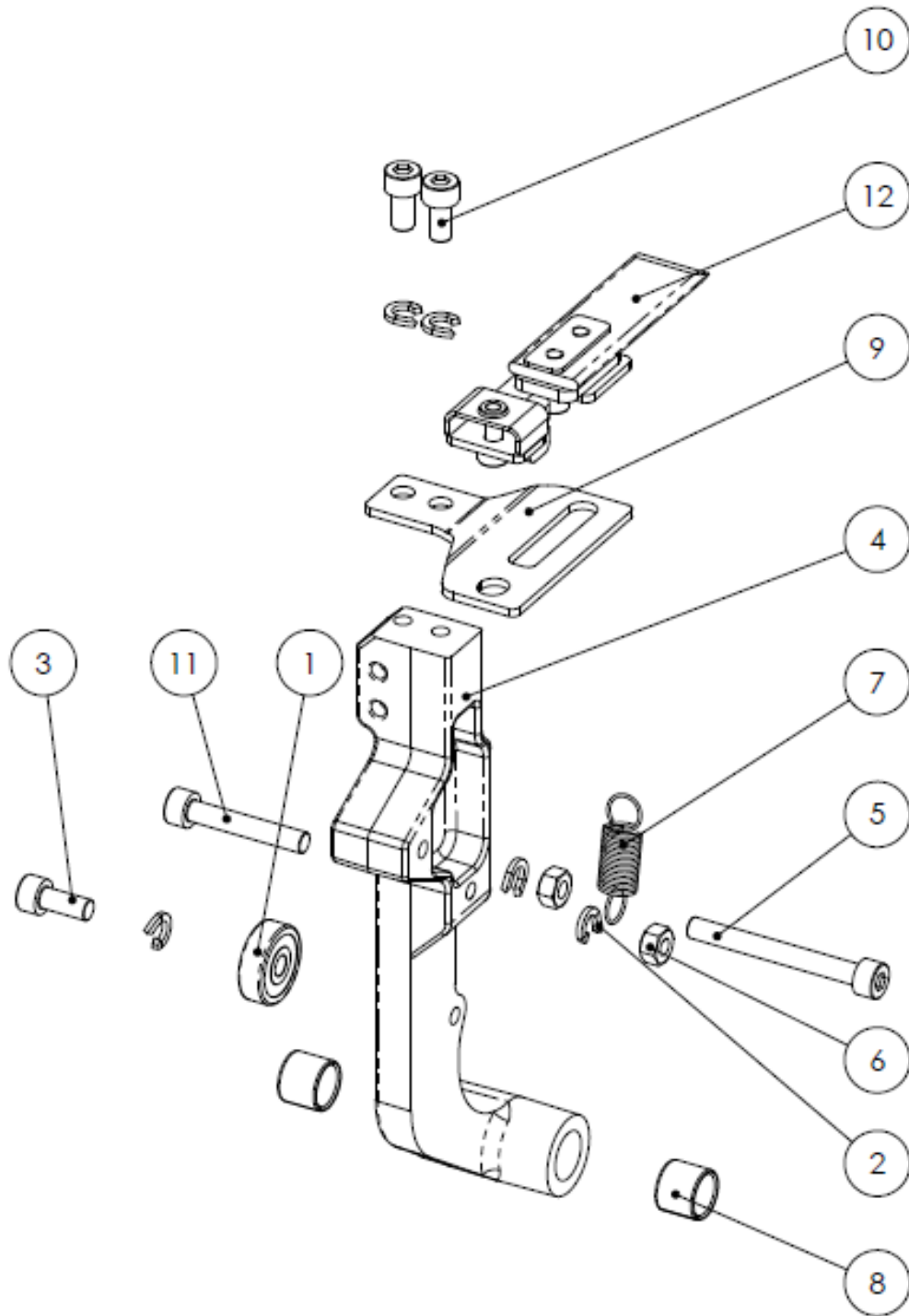

FIGURE 9-1 HEATER PLATE UNIT			
NO.	PART NUMBER	DESCRIPTION	QTY
1	P1104-020635ZZ2	BALL BEARING 635ZZ	1
2	P1103-0205Z	SPRING WASHER ϕ 5	5
3	P1101-0505012AN	SCREW M5*12	1
4	P02-0357600	SEPARATOR ARM	1
5	P1101-0505045AN	SCREW M5*45	1
6	P1102-0105AN	NUT M5	2
7	P1202-0011700	HEATER PLATE SPRING	1
8	P1104-0310101	BUSHING CB1010	2
9	P01-0577000	HEATER PLATE SUPPORT	1
10	P1101-0505010AN	SCREW M5x10	2
11	P1101-0505030AN	SCREW M5*30	1
12	P02-0362300	HEATER PLATE ASSEMBLY	1

FIG. 10-1 BODY FRAME

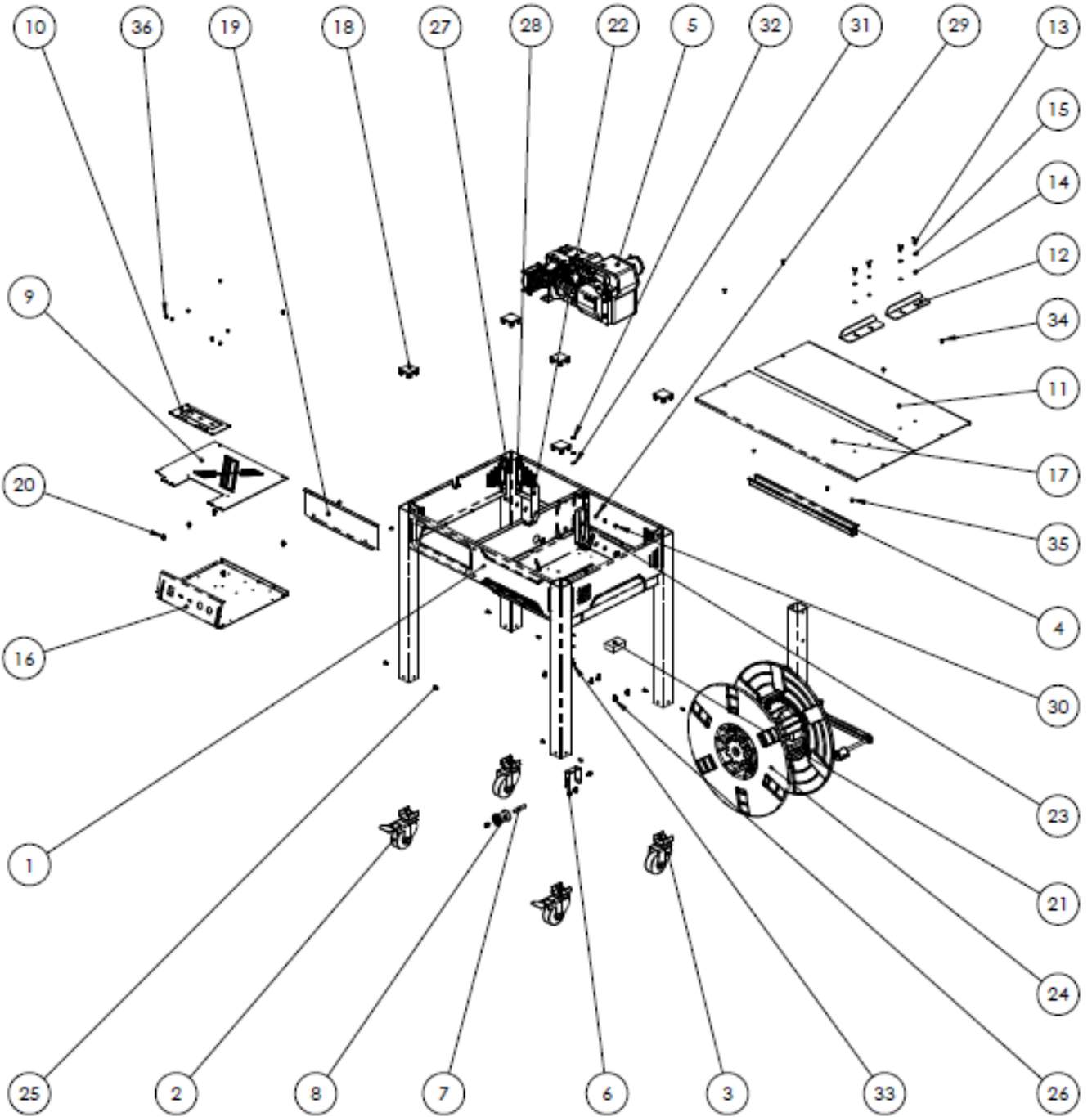

FIGURE 10-1 BODY FRAME			
NO.	PART NUMBER	DESCRIPTION	QTY
1		CABINET COMPONENTS	1
2	P02-0362700	CASTER	2
3	P02-0362800	CASTER WITH BRAKE	2
4	P01-0579400	TRACK	1
5		STRAPPING HEAD UNIT	1
6	P01-0584300	GUIDE ROLLER BRACKET	1
7	P02-0076400	GUIDE ROLLER PIN	1
8	P06-002150A	GUIDE ROLLER	1
9	P01-058000A	ELECTRICAL BOX COVER	1
10	P01-057840A	PANEL COVER	1
11	P01-0580200	REAR TABLE COVER	1
12	P01-057810A	BOX STOPPER	2
13	P1101-1105012AZ	SCREW M5*12	4
14	P1103-010510N	WASHER $\phi 5*10$	4
15	P1103-0205Z	SPRING WASHER $\phi 5$	6
16	P01-0579900	ELECTRICAL BOX	1
17	P01-0580100	FRONT TABLE COVER	1
18	P1114-01000020B	PLASTIC CAPS	6
19	P01-0585000	ELECTRICAL BOX REAR SUPPORT	1
20	P1101-0905012AN	SCREW M5*12	5
21	P06-002200A	CUSHION	1
22	P01-0588000	SUPPORT PLATE	1
23	P01-0588100	SUPPORT BRACKET	1
24		DISPENSER ASSEM	1
25	P1101-0605010BN	SCREW M5*10	12
26	P1101-0906012AN	SCREW M6*12	10
27	P1101-0506020AN	SCREW M6*20	2
28	P1103-0206Z	SPRING WASHER $\phi 6$	4
29	P1103-01061301Z	WASHER M6x13x1t	4
30	P1102-0106AZ	NUT, M6	2
31	P1103-01051201Z	WASHER M6x13x1t	2
32	P1102-0105AZ	NUT, M5	1

FIGURE 10-1 BODY FRAME			
NO.	PART NUMBER	DESCRIPTION	QTY
33	P1101-0505016AN	SCREW M5*16	1
34	P1101-0405012AN	SCREW M5*12	4
35	P1101-0404008AN	SCREW M4*8	3
36	P1101-0104006AZ	SCREW M4*6	10



FIG. 11-1 DISPENSER ASSEMBLY

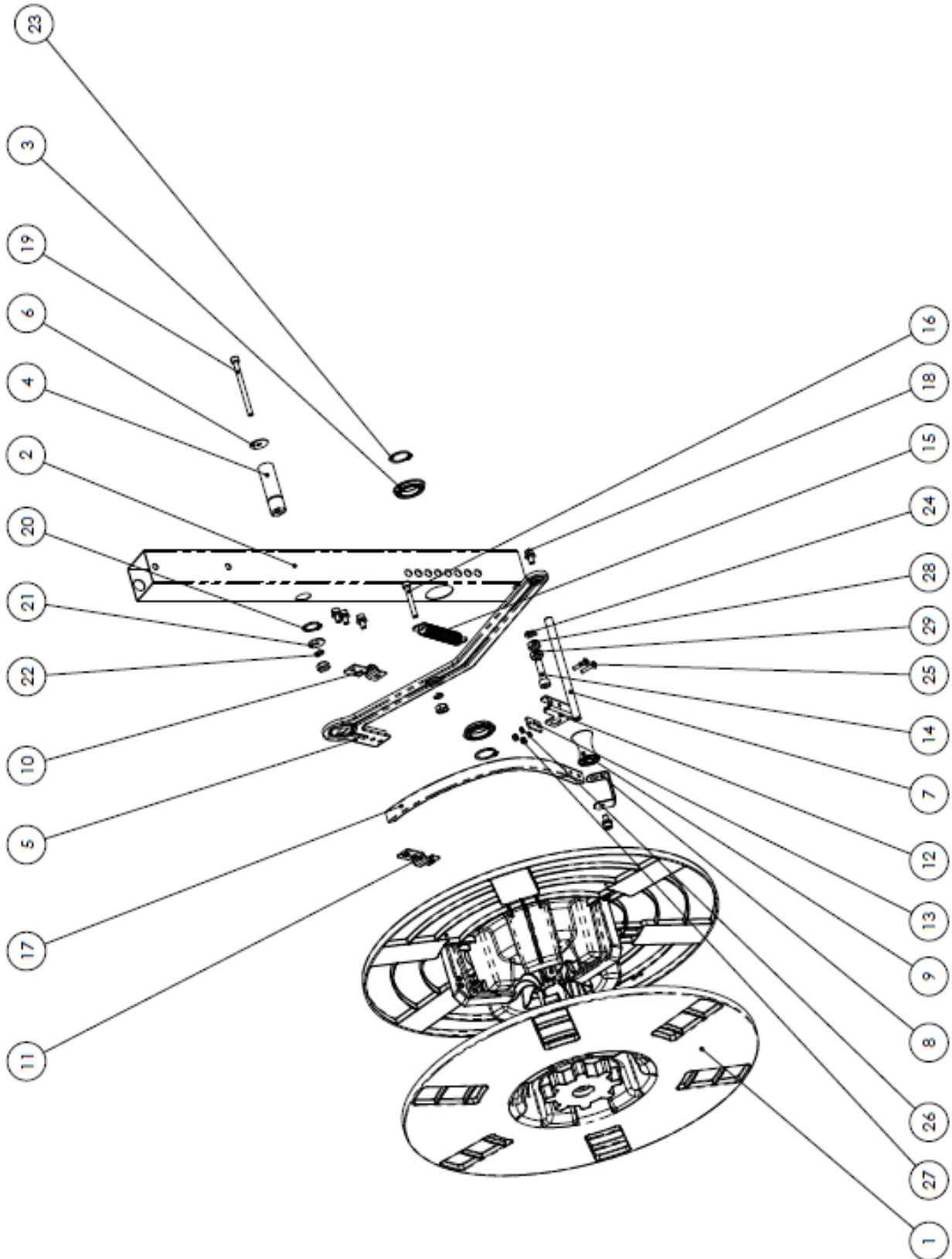

FIGURE 11-1 DISPENSER ASSEMBLY			
NO.	PART NUMBER	DESCRIPTION	QTY
1		DISPENSER UNIT	1
2	P01-0579200	DISPENSER SEAT	1
3	P1104-076805ZZ0	BALL BEARING 6805ZZNR	2
4	P02-035940A	BRAKE SUPPORT SHAFT	1
5	P01-0578000	BRAKE ARM	1
6	P01-0584500	BRAKE WASHER	1
7	P02-0359300	ROLLER SHAFT	1
8	P01-0584100	ROLLER BRACKET	1
9	P06-000680B	ROLLER	1
10	P01-0578300	BELT PLATE - FRONT	1
11	P01-0584600	BELT PLATE - REAR	1
12	P01-057820A	BELT FIXER	1
13	P01-058420A	BELT ADJUST PLATE	1
14	P1101-0508030AN	SCREW M8*30	1
15	P1202-0012500	BRAKE SPRING	1
16	P1101-0506045AZ	SCREW M6*45	1
17	P0902-0001400	V-BELT	1
18	P1101-0906012AN	SCREW M6*12	5
19	P1101-0506080AN	SCREW M6*80	1
20	P1105-0120B	C-RING S-20	1
21	P1103-01062102Z	WASHER M6x21x2t	1
22	P1103-0206Z	SPRING WASHER ϕ 6	2
23	P1105-0125B	C-RING S-25	2
24	P1103-0208Z	SPRING WASHER ϕ 8	1
25	P1101-0104020AZ	SCREW M4*20	2
26	P1103-0204Z	SPRING WASHER ϕ 4	2
27	P1102-0104AZ	NUT, M4	2
28	P1102-0108AZ	NUT, M8, 12MM	3
29	P1102-0108BZ	NUT, M8	1

FIG. 12-1 DISPENSER UNIT

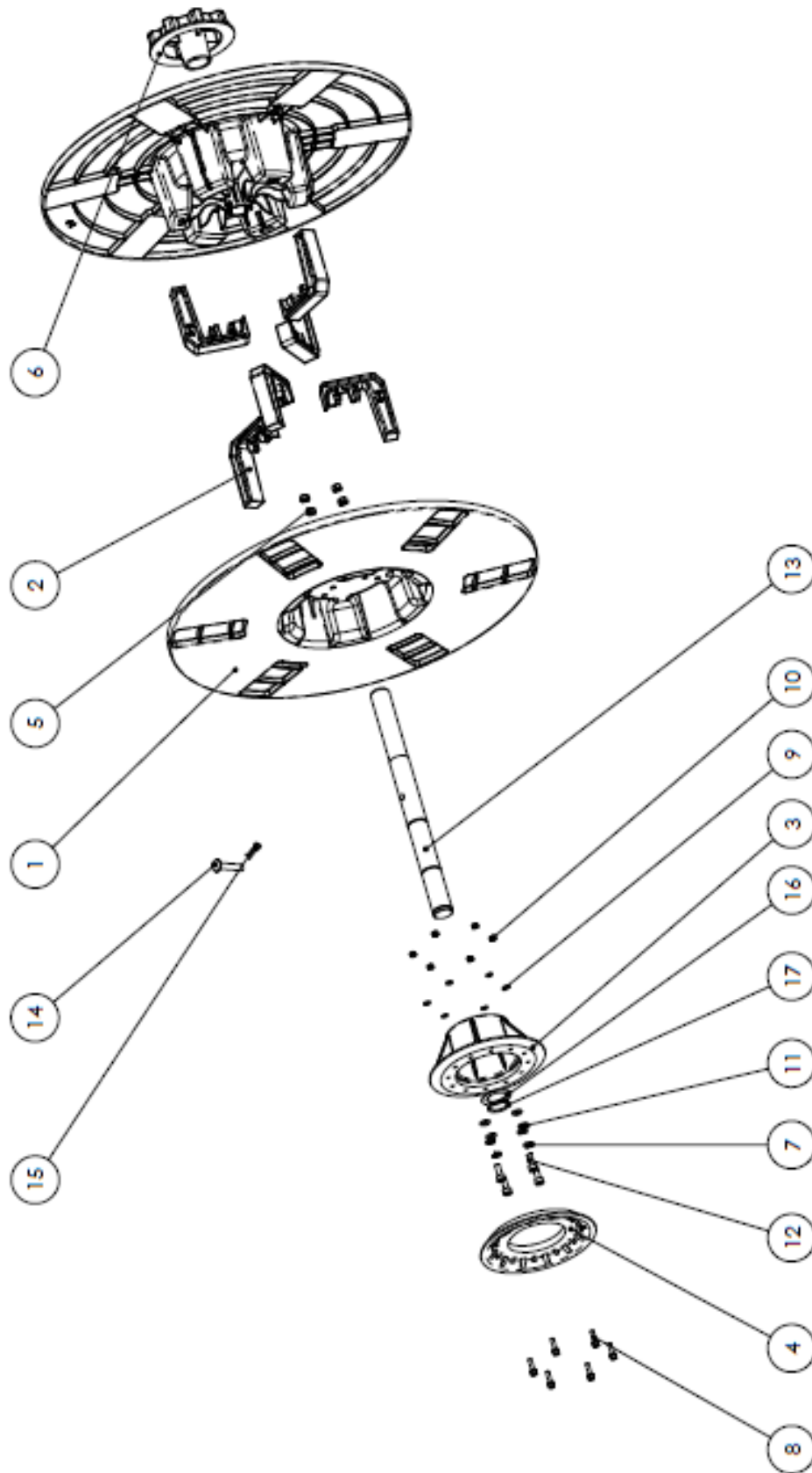

FIGURE 12-1 DISPENSER UNIT			
NO.	PART NUMBER	DESCRIPTION	QTY
1	P06-0058200	DISPENSER	2
2	P06-0058500	EXTENSION CLAW	6
3	P06-0058300	DISPENSER CONNECT	1
4	P06-0058400	BRAKE WHEEL	1
5	P1102-0106AZ	SCREW M6	4
6	P06-0058100	DISPENSER HANDLE	2
7	P1103-0206Z	SPRING WASHER ϕ 6	4
8	P1101-0904018AN	SCREW M4*18	6
9	P1103-01040801Z	WASHER M4*8*1t	6
10	P1102-0104AN	NUT M4	6
11	P1103-010612N	WASHER ϕ 6*12*1t	4
12	P1101-0506016AN	SCREW M6*16	4
13	P02-0313700	DISPENSER SHAFT	1
14	P02-0076300	LOCK PIN	1
15	P1109-030801Z	SNAP PIN 08	1
16	P01-0584400	DISPENSER SPACER	1
17	P1105-0125B	C-RING S-25	1

