

# AUTOMATIC STRAPPING MACHINE



## GPAS-158

# OPERATION MANUAL

2022-2-16



02 9452-3566  
sales@getpacked.com.au



## EC Declaration of Conformity

According to the following EU Directives:

- Machinery Directive: 2006/42/EC
- Low Voltage Directive: 2014/35/EU
- Electromagnetic Compatibility Directive: 2014/30/EU

We, [EXTEND GREAT INTERNATIONAL CORP.](#)

[Add: 20F, No. 309, Sec. 2, Taiwan Blvd., Taichung, Taiwan R.O.C](#)

[Tel: +886-4-2326-5568](#) [Fax: +886-4-2326-2268](#)

Declare that the machines mentioned hereafter:

☉**Product: Strapping Machine**

☉**Model: EXS-158**

☉**Serial No.:**

☉**Functions: They are used for packaging products by polypropylene strap**

They are designed and manufactured in compliance with the essential health and safety requirements of the Machinery Directive and Electromagnetic Compatibility Directive, and are based on the following European harmonized standards:

- EN 415-1:2000+A1:2009, Safety of packaging machines - Part 1: Terminology and classification of packaging machines and associated equipment
- EN 415-8:2008, Safety of packaging machines - Part 8: Strapping machines
- EN ISO 12100:2010, Safety of machinery - General principles for design - Risk assessment and risk reduction
- EN ISO 13849-1:2008, Safety of machinery – Safety related parts of control systems Part 1: General principles for design
- EN 60204-1:2006+AC:2010, Safety of machinery - Electrical equipment of machines - Part 1: General requirements
- EN 55011:2009+A1:2010, Electromagnetic compatibility - Industrial, scientific and medical (ISM) radio-frequency equipment- Radio disturbance characteristics- Limits and methods of measurement
- EN 61000-4-2:2009, Electrostatic discharge (ESD)
- EN 61000-4-4:2012, Electrical fast transient/burst requirements (EFT/Burst)
- EN 61000-4-6:2014, Immunity to conducted disturbances, induced by radio-frequency fields (CS)

Authorized representative in European Community: (if applicable)

Representative : \_\_\_\_\_  
*Robert Lai / President*

Place / Date : *Taichung City, Taiwan. / April 22, 2016.*

# 1 GENERAL SAFETY INSTRUCTIONS

1.1	Basic Operation .....	5
1.2	Basic Safety Precautions .....	5
1.3	Safety Instructions Governing Specific Operational Phases .....	6
1.4	Warning of Electrical Dangers .....	7
1.5	Grounding Instructions Shall Include the Following .....	8
1.6	Before Operating .....	9
1.7	During Operation .....	9
1.8	After operating .....	9
1.9	Signs .....	10

# 2 MACHINE INFORMATION

2.1	Areas of Application .....	11
2.2	Environmental Information .....	12
2.3	Machine Description .....	13
2.4	Safety Devices .....	14
2.5	Technical Specification .....	16
2.6	Identification Data of the Machine .....	17

# 3 BEFORE OPERATING THE MACHINE

3.1	Shipping .....	18
3.2	Transportation & Unload Machine from Pallet .....	18
3.3	Installation .....	19
3.4	Operation Space .....	20
3.5	Operation Elements .....	21
3.6	Auto Threading of Polypropylene Strap .....	22

## **4 OPERATING THE MACHINE**

4.1	Main Page .....	24
4.2	Operation Mode Page .....	25
4.3	Setting Page .....	26
4.4	Service Mode Page .....	27
4.5	Factory Setting Page .....	28
4.6	Counter Page.....	28

## **5 ADJUSTMENT**

5.1	Strap amount in the Pool Box .....	29
5.2	Pool Feed pressure & gap .....	30
5.3	Feeding / Refeeding pressure & gap .....	31
5.4	Tension .....	32
5.5	Brush in Arch .....	33
5.6	Change between 9mm and 12mm.....	34

## **6 TROUBLE SHOOTING..... 38**

## **7 MAINTENANCE..... 40**

## **8 ELECTRIC WIRING DIAGRAM & PART..... 42**

## **9 PART LIST..... 46**

# 1. GENERAL SAFETY INSTRUCTIONS

## 1.1 Basic Operation

- The manual and the safety remarks are to be read before use. The operator manual should be kept with the machine at all times. Intervals for maintenance and inspections are to be adhered to.
- This machine was built with state of the art technology and rigid adherence to safety standards.
- Unless used properly, it can cause injury to operators or persons in close proximity to the machine. In addition, improper use can cause damage to the machine or property around the machine.

## 1.2 Basic Safety Precautions

- The user is to be instructed in all other generally applicable legal and other mandatory regulations relevant to accident prevention and environmental protection in addition to the operating instructions.
- For safety reasons, long hair must be tied back or otherwise secured, garments must be close fitting and no jewelry may be worn.



- Use protective equipment whenever required by circumstances or by law.
- Carefully observe all safety instructions and warnings attached to the machine and make sure that they are always complete and perfectly legible.
- Always make certain that persons being trained and instructed in working on or with the machine are permanently supervised by an experienced person.
- Work on the electrical system and equipment of the machine is only to be carried out by a skilled electrician or by persons under the supervision and guidance of a skilled electrician and in accordance with the rules and regulations of electrical engineering.

### **1.3 Safety Instructions Governing Specific Operational Phases**

- Avoid any operation mode that might be unsafe.
- All necessary precautions to ensure that the machine is only used being in a safe and reliable state are to be taken. The machine is only to be operated if all protective and safety devices, including removable safety devices, emergency shut-off equipment, noise-protection elements and exhaust systems are in right place and fully functional.
- The machine is to be checked for damage and defects at least once per work shift. Any changes including the working behavior of the machine are to be reported to competent persons immediately. If necessary, the machine is to be stopped and locked immediately.
- In case of any malfunction the machine must be stopped and locked until the defect has been eliminated.
- Generally make sure that nobody is at risk before starting up the machine.
- All personnel that will be operating this machine should be thoroughly trained in all phases of operation and safety.
- Always tighten unscrewed connections after maintenance and repair.
- After completing maintenance and repair all safety devices removed for setting up or repairing the machine must be reinstalled and checked for functionality prior to putting the machine back into service.
- To minimize the environmental impact all consumables and replaced parts must be disposed of safely.
- Before starting the machine check that the accessories have been stowed away safely.
- Do not attempt any operation that may be a risk to the stability of the machine.

## 1.4 Warning of Electrical Dangers



- Immediately remove power to the machine in case of trouble in the electrical system.
- Replace a fuse with one with the same style and ratings; pay particular attention to matching the specified current.
- Any electrical work performed on the equipment must be conducted by a skilled electrician or under the supervision of a skilled electrician. All work must be observed good electrical engineering practice and follow safety rules and local wiring standards.
- Inspect the electrical equipment of the machine at regular intervals. Tighten any loose connections. Check wiring for scorch marks; replace scorched wiring and determine and correct the reason for the overheating.
- When working on live equipment, ensure that a second person is available to cut power in case of an emergency. When appropriate, secure the working area with safety tape and a warning sign. Use insulated tools for electrical work.
- Before working on high-voltage assemblies, turn off the power supply. Carefully discharge the supply cable and short-circuit any energy-storage components such as capacitors.
- If the equipment was moved, carefully refit and refasten all parts removed for transport before reapplying power.
- Before moving the machine, remember to disconnect the power cable.

## 1.5 Grounding Instructions Shall Include the Following

- This product must be grounded. In the event of an electrical short circuit, grounding reduces the risk of electric shock. This product is equipped with a cord that has a grounding wire and an appropriate grounding plug. The plug must be plugged into an outlet that is properly installed and grounded in accordance with all local codes and ordinances.
- If repair or replacement of the cord or plug is necessary, connect the ground wire to the ground terminal of the plug. The wire with green insulation (with or without yellow stripes) is the grounding wire.
- Check with a qualified electrician or service person if the grounding instructions are not clear or if in doubt about the proper grounding of the machine. Do not modify the plug provided; if it will not fit the power outlet, have the proper outlet installed by a qualified electrician.
- This product is designed for use on a nominal 230 volt AC circuit and has a grounding plug.

**DANGER!**

**Improper installation of the grounding can result in electrocution.**



## 1.6 Before Operating

- Verify that the power line voltage is correct.
- The machine must be properly grounded to avoid a shock hazard. All wiring must be in accordance with local wiring standards.
- The strapping machine can only be operated with polypropylene (P.P.) strapping; do not use polyester (PET) strapping or polyethylene (PE) cord strap.

## 1.7 During Operation








- The weight of the package cannot exceed 70kg. For package weight over 25kg, it may be necessary to use lifting aids for handling; while package weight over 40kg, it's necessary to handle it with conveyor system.
- The size of the package should not be less than 70 mm × 20 mm (2.75 inches × 0.75 inches).
- While running, check the unit for any unusual sounds or smoke emissions.
- Keep away from the inside of the arch while the machine is operating; do not you're your hands or body into the arch when the machine is running.

**NOTE: It is normal for the heater tongue to smoke during the sealing operation.**

## 1.8 After operating

- Remove dust and dirt from the unit
- Turn off the power when the machine is not in use.

## 1.9 Signs

	<p><b>Caution!</b> <b>Electric Shock Hazard.</b></p>
	<p><b>Caution!</b> <b>Hot Surface.</b></p>
	<p><b>Caution!</b> <b>Moving Parts Can Crush Hand.</b></p>
	<p><b>Caution!</b> <b>Pinch Point Entanglement</b></p>
	<p><b>Caution! Blade.</b> <b>Cutting of Fingers or Hand</b></p>
	<p><b>Wear Eye Protection</b></p>
	<p><b>Refer to Operator Manual</b></p>

## 2. MACHINE INFORMATION

### 2.1 Areas of Application

This plastic strapping machine can be used for a wide range of applications where the minimum package width is at least 70mm, and the minimum height is 20mm.

This machine is particularly suitable for heavy packaged goods as well as printed products, boxes, etc.

Packaging Limitation

It's not possible to pack:

- Products larger or heavier than that allowed.
- Wet Products
- Flammable products
- Explosive products
- Agri-foodstuffs
- Pharmaceuticals
- Hazardous products

## 2.2 Environmental Information

The strapping machine shall be installed in the following conditions:

- Supply voltage: +/-10% nominal supply voltage
- Source frequency: +/-10% nominal frequency
- Ambient temperature: 5°C - 40°C (41°F-104°F).
- Relative humidity: not exceed 35~85%RH
- Please provide a suitable illumination around the machine for safety operation.

### Conditions For Use

Make sure there is room for easy application and maintenance

The machine must be installed in a closed, well-ventilated area where there are no explosions or fire hazards Position the machine in a place free of humidity, flammable materials, gas or explosives. Make sure that it is level.

Please do not spray water or wet wipe machine body.

### Noise - characteristic values

The noise emission values determined according to EN ISO 3746 for the sound power level or EN ISO 11202 for the sound pressure level at the workplace on the basis of the working conditions are as below:

A measurement uncertainty allowance of  $K = 4 \text{ dB(A)}$  applies to the stated emission values.

Sound power level  $L_{WA} = 88.7 \text{ dB(A)}$

Emission sound pressure level at the workplace  $L_{PA} = 75.3 \text{ dB(A)}$

To minimize the emission sound pressure level, machine is equipped with a timer standby mode that can be adjusted by technician.

### Demolition and Waste Disposal

The machine does not contain dangerous components or substances which require special disposal procedure. For that which concerns material elimination, comply with the Standards in the country where the machine has been disassembled.

**Caution: do not leave waste polypropylene strap on the floor to minimize slip hazards.**

## 2.3 Machine Description

- Automatic strapping machine for polypropylene (PP) strapping material.
- Strap width 9-12mm adjustable.
- High efficiency heater plate.
- Front & rear table are hinged with quick release structure.
- Loop ejection in case of strapping cycle without package.
- Extra strong construction.
- Simple and user-friendly operation.
- Automatic strap threading system.
- Automatic strap end detection and ejection.
- Dispenser inside cabinet for safety
- Table made of stainless steel.
- Strap tension adjustable from soft to very high.
- Automatically second try feed function to increase efficiency

## 2.4 Safety Devices

### **DANGER!**

**Operate the machine only when all safety devices are at their place and are functioning correctly.**

The machine has been constructed in accordance with the applicable legal regulations.

The machine is reliable in operation. Nevertheless the machine may constitute a danger if it is operated in improper or undue condition.

Danger points that cannot be avoided due to equipment design are equipped with safety devices. If necessary, these points are marked on the machine with warning signs, and in the manual under working safety instructions.

The machine is equipped with safety devices as:

- Warning labels
- Live parts are covered
- Table cover with screw fixed (1)

Only Polypropylene strapping can be used in this machine. The use of other synthetic Straps can produce substances hazardous to health.

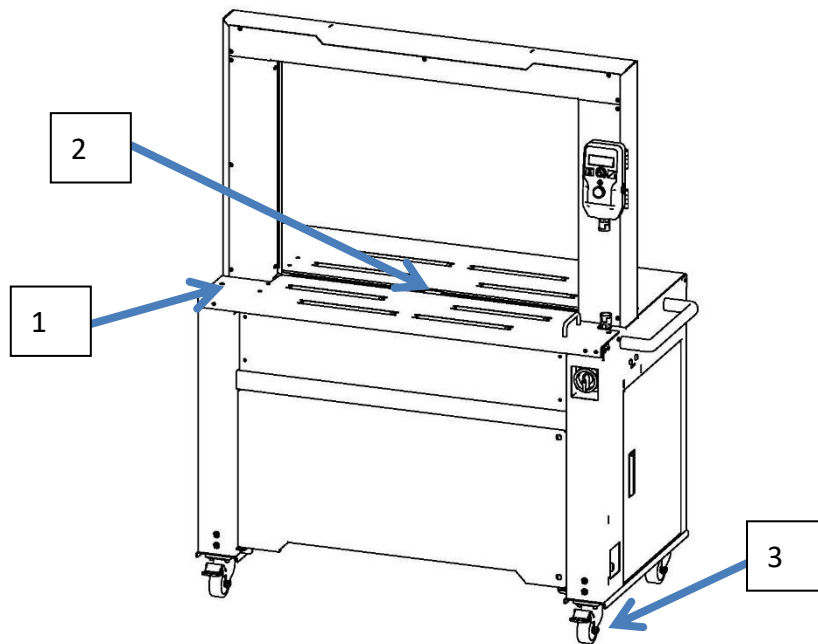


Caution!

The heating unit operates at a very high temperature in order to melt the P.P. strapping.

To prevent burns, avoid contact with this area. (2)

To move the machine, the two lockable casters (3) must be unlocked. Relock the two casters when the machine is in its new position.



The machine is turned on when it is connected to AC power and the main power switch, located on the front operating panel, is placed in the ON position. After approximately 1 minute, the heating element will reach its operating temperature and the machine will be ready for use.

If it is necessary to make adjustments inside the machine during operation, after a strap jam for example, the table top can be unscrewed. Observe caution as the machine is still fully functional with the covers removed. If machine with safety switch, when table top is opened, safety switch is activated. This will remove power but heating element is keeping heating.



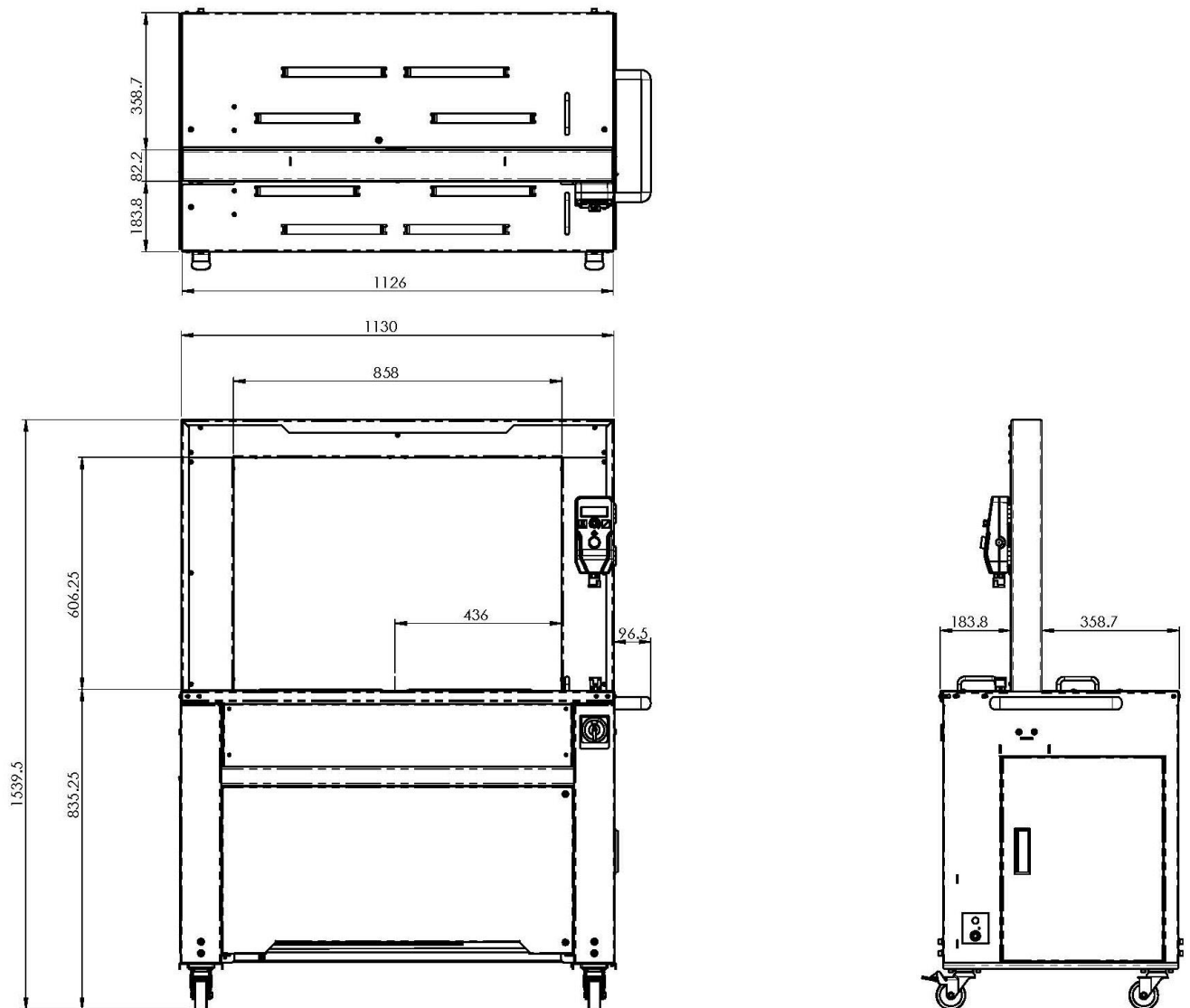
Caution!

## 2.5 Technical Specification

### 2.5.1 Electrical Specification

System Configuration	L1+N+PE (GROUND)	L1+N+PE (GROUND)
Nominal Power	0.72 kW	0.72 kW
Rated Current	3.1 A	6.5 A
Rated Voltage	200V/220V/230V/240V	100V/110V
Rated Frequency	50 Hz	60 Hz
Type of Current	AC- single phase	AC – single phase

### 2.5.2 Technical information

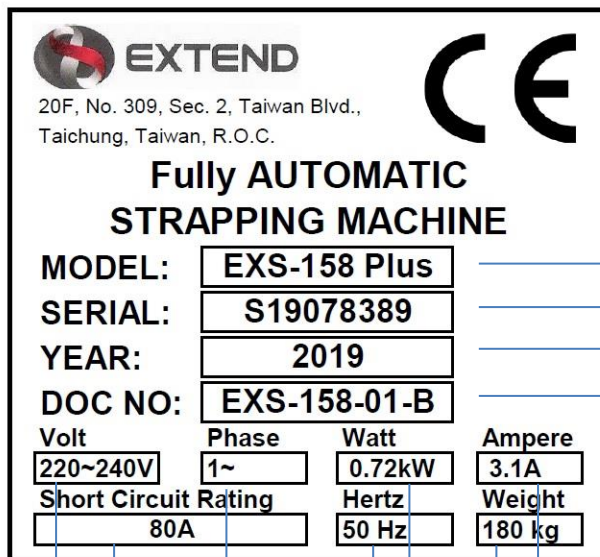




STRAP WIDTH	9mm/12mm ONLY (BY ADJUSTMENT)
STRAP THICKNESS	0.45mm – 0.7mm
STRAP COIL	Coil diameter: 200mm (230mm/280mm as option) Width: 190mm-200mm
MACHINE SIZE	1130mm (L)* 619mm (W) * 1535mm (H)
NET WEIGHT	180 Kg
TENSION RANGE	50 N – 650 N
SPEED	37 STRAP/MIN
TABLE HEIGHT	835mm
NOISE EMISSION	78 dB
AMBIENT TEMP.	5°C - 40°C
MIN PACKAGE SIZE	70mm*20mm
MAX PACKAGE SIZE	850mm*600mm (standard arch size)

## 2.6 Identification Data of the Machine

Each model is provided with a plate where it is easy to recover data which must be communicated to the manufacturer in case of problem or when requesting spare parts etc. (ref. 1-2-3-4) This plate also carries electrical technical data for installation of the machine. (ref. a-b-c-d-e-f-g).



a      b      c      d      e      f      g

1. Model
2. Serial Number
3. Year of Manufacture
4. Doc. Number
  
- a. Rated voltage (V)
- b. Rated Current (A)
- c. Frequency (Hz)
- d. Short Circuit Rating (A)
- e. Phase (PH)
- f. Rated power (Watts)
- g. Weight (kg)

### 3. BEFORE OPERATING THE MACHINE

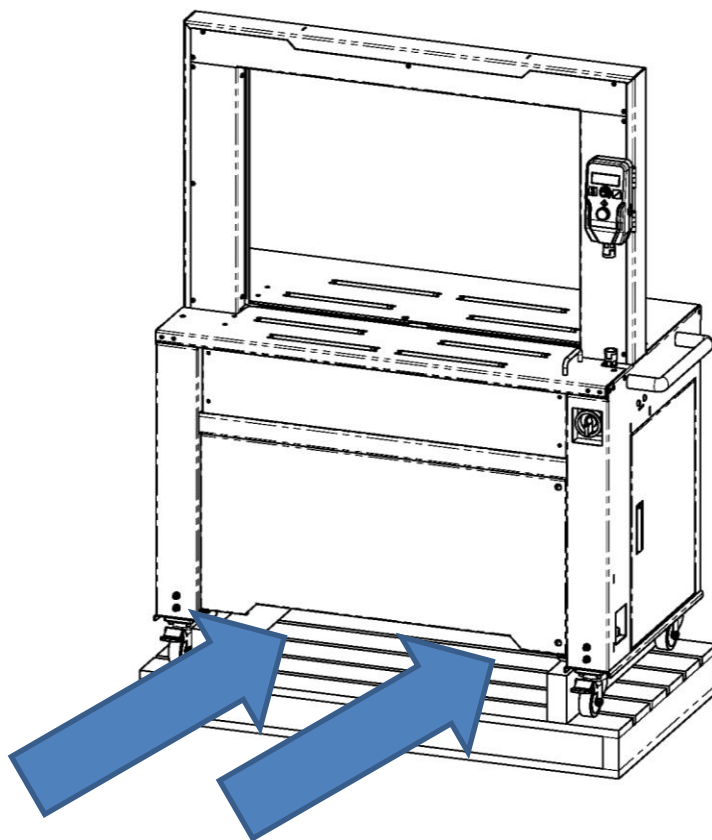
#### 3.1 Shipping

The machine is delivered as a transport unit. The machine is loaded onto a wooden pallet with Polyester strap secured. Outside with carbon box also with Polyester strap secured.

#### 3.2 Transportation & Unload Machine from Pallet

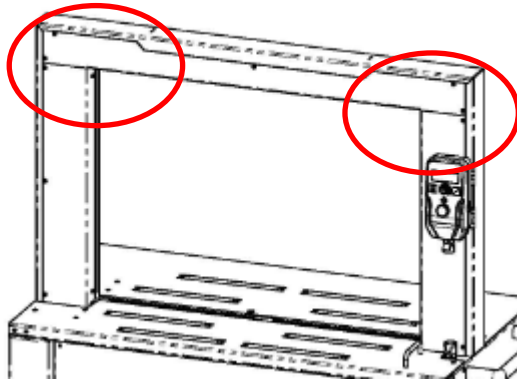
The machine needs to be secured well on wooden pallet. The side edge of machine body needs to be sitting on the pallet to make sure casters are free (1). Remove protection material around the machine like stretch film and plastic cover, and then do remove the Polyester strap.

Please carry the machine by having forklift's fork under the machine, be careful if you have foot bar switch to avoid not damaged from the forklift.



### 3.3 Installation

- a. Remove packaging material and check if the machine is complete without any transportation damage
- b. Remove cushion material inside corners of the arch.

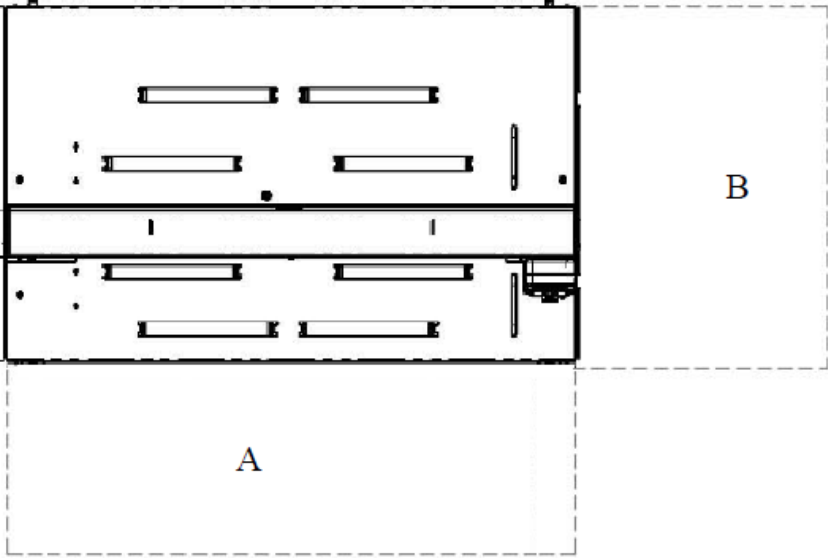


- c. After positioning the machine, do make sure lock brake of casters (two front casters with brake)

Note: when moving the machine again, do remember to unlock the brake of casters, then relocate and lock again.

Note: when moving the machine, do turn the machine power off and make sure cable is on the table in case cable damaged.

### 3.4 Operation Clearance



Keep the area (A) and (B) free for the operator.

The area (A) is necessary for operating strapping machine.

The area (B) is necessary for changing the strap.

### 3.5 Operation Elements

**a. Main Power Switch:**

Provide the machine with Power. Switch to "I" for ON to operate the machine; switch to "—" for OFF to shut power off.



**b. LCD Display:**

Indicate condition and error message of the machine

**c. Page Select:**

This button is to select pages of function of this LCD Display.

**d. Soft Tension:**

In the main page, this button could switch between tension and soft tension.

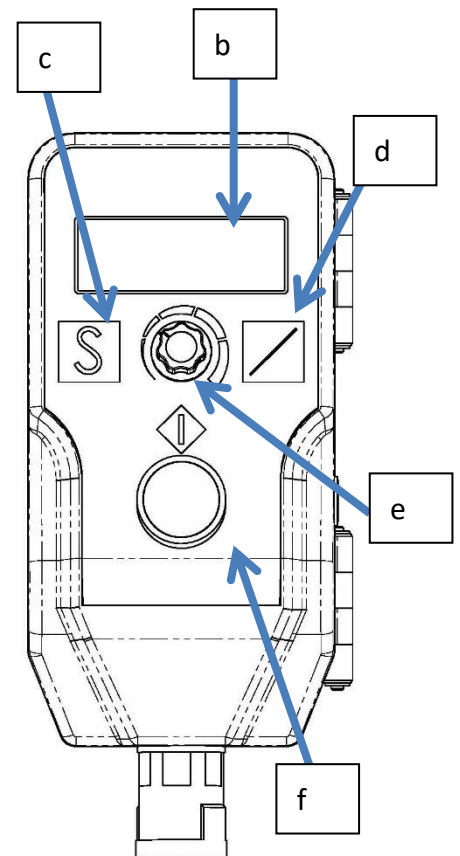
Besides the main page, this button could work as "home page" button.

**e. Potentiometer:**

Press down to select/confirm. Rotate clockwise to increase value, and rotate counter clockwise to decrease value.

**f. Start Button:**

To start machine with select operation



## **3.6 Auto Threading of Polypropylene Strap**

### **3.6.1 Strap Specification**

Material: Polypropylene Strap

Width: 9mm/12mm only adjustment

Thickness: 0.45mm-0.7mm (any strap outside this range, please contact EXTEND for further studying)

Core diameter: 200mm (230mm and 280mm as option)

Core width: 190mm-200mm

Strap with excessive chamber (5mm with 200cm length) cannot be used.

### **3.6.2 Strap Coil Installation**

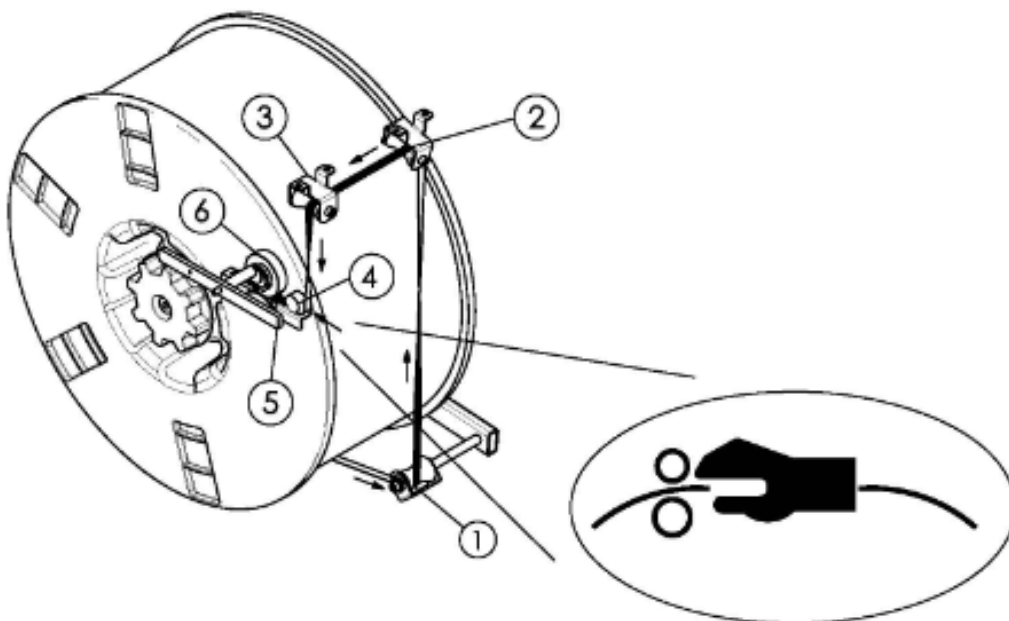
- a. Open the side door
- b. Release the Reel Nut Handle by clockwise rotation
- c. Take out the outer flange
- d. Remove the old strap coil or other dust material, then install the new strap coil onto the drum according to the direction shown on dispenser label
- e. Put back the outer flange and right the Reel Nut Handel by counter clockwise rotation.
- f. Remove the protect straps and the sticker on the new strap coil.

### 3.6.3 Auto Thread Function

- a. Turn on the main power switch
- b. Press “Start Button” to make machine self-detect
- c. Make sure LCD display showing “REMOVE LAST STRAP, LOAD NEW STRAP”
- d. Make sure no previous strap left in the chute
- e. Thread strap as indicate picture/sticker through three guide rollers (1,2,3)
- f. Keep threading strap until it hits the pool feed rollers (6), at this moment the strap indicator (4) should be light off
- g. Lift the lever (5) and further insert the strap around 2-3 cm ahead the rollers
- h. Check LCD Display, it will show “AUTO THREAD, PUSH START BUTTON”
- i. Press “Start Button” to start auto threading function

**Note: If the strap is fed too much more than 5 cm ahead roller, it could cause auto threading fail.**

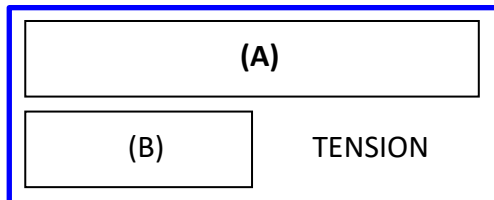
**Note: Please make sure PP strap is in correct curve down direction, to have the PP strap insert into machine in opposite direction, it might cause auto threading, feed, refeed...functions not stable.**



## 4. OPERATING THE MACHINE

There are many functions of the machine in LCD Display, showing as below

### 4.1 Main Page



Main page shows current situation of machine and also is able to adjust tension setting.

(A) Shows current strapping mode (operation mode):

➤ MANUAL STRAP READY

It means under manual mode, the machine will do strap only when operator press Start Button.

➤ AUTO STRAP READY

It means under auto 1 strap mode, the machine will automatically do one strap when table sensor is ON

➤ CONTI STRAP READY

It means under continuous strap mode, the machine will automatically keep doing straps until table sensor is OFF

(B) Shows current tension setting:

➤ 0% - 100%:

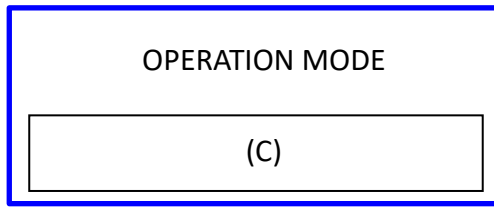
When operator press the Potentiometer, this number will twinkle, then operator could rotate Potentiometer to change the value. And operator can press the Potentiometer again to confirm the value.

➤ SOFT:

No matter what is current tension setting, as long as operator pressing SOFT TENSION Button, then the machine will directly go to soft tension mode. If the Operator press SOFT TENSION Button again, then the machine will go back to set tension value.



## 4.2 Operation Mode Page



Operation Mode allows operator to change strapping mode.

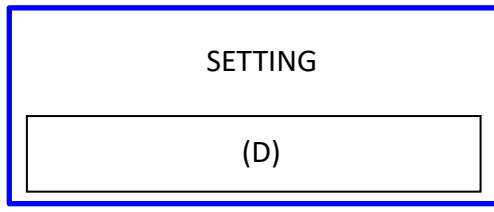
(C) Shows strapping mode and detail setting of mode. Operator could press Potentiometer, then the (C) will twinkle then it's allowed to change to different mode

- MANUAL STRAP → push Potentiometer to confirm → back to Main Page (shows MANUAL STRAP READY)
- AUTO STRAP → push Potentiometer to confirm → T1 DELAY \_\_ S (this timer means the delay time after package is on the table sensor, from 0.0 to 5.0) → rotate Potentiometer to set value then press to confirm → back to Main Page (shows AUTO STRAP READY)
- CONTI STRAP → push Potentiometer to confirm → T1 DELAY \_\_ S (this timer means the delay time for 1st strap after package is on the table sensor, from 0.0 to 5.0) → rotate Potentiometer to set value then press to confirm → T2 DELAY \_\_ S (this timer means for all following straps time gap until package is out of the table sensor, from 0.0 to 5.0) → rotate Potentiometer to set value then press to confirm → back to Main Page (shows CONTI STRAP READY)

**Note: T1 delay time is shared for AUTO STRAP and CONTI STRAP**

**Note: During your setting adjustment, if idles over 10 seconds, it will automatically go back to Main Page with your current setting.**

### 4.3 Setting Page



(D) Shows current setting of machine, operator could change the setting through the Potentiometer.

➤ COOLING TIME \_\_ S:

This is strap welding cooling timer adjust. If you have big tension with hard package, longer cooling time could help you with better seal on strap.

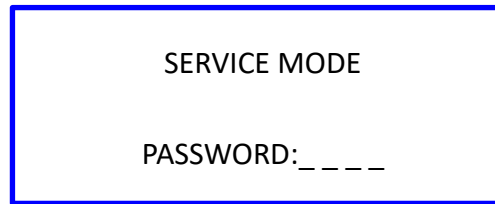
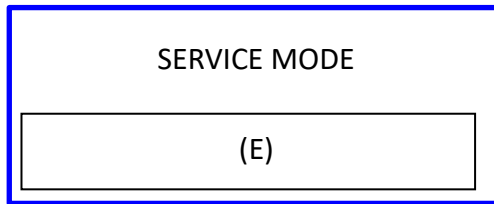
Press Potentiometer → number \_\_ will start twinkle → rotate Potentiometer to change value (from 0.0 to 1.0) → press Potentiometer to confirm

➤ HEATER TEMP \_\_\_ %

This is heater plate temperature setting. This setting is depend on working environment and strap material, sometime cooler surrounding temperature or thicker strap material would need higher temperature setting on the heater plate.

Press Potentiometer → number \_\_ will start twinkle → rotate Potentiometer to change value (from 0 to 100) → press Potentiometer to confirm

#### 4.4 Service Mode Page



For service only, this function allows technician go detail check (password protect, please contact for password), you could rotate the Potentiometer to select manual function then press Start Button to run.

- FEED  
Press Start button to manual run M2 motor forward
- REFEED  
Press Start Button to manual run M2 motor backward
- CAM  
Press Start Button to manual run M1 motor forward
- 2<sup>nd</sup> FEED SOLENOID  
Press Start Button to activate 2<sup>nd</sup> feed solenoid
- AUTO FEED MOTOR  
Press Start Button to run auto threading motor
- Language (Option)  
Rotate the nut for switch language & Press Start Button to confirm

#### 4.5 Factory Setting Page

FACTORY SETTING

PASSWORD: \_ \_ \_ \_ \_

This is for factory setting usage only, change the setting will have no warranty protect.

#### 4.6 Counter Page

COUNTER

COUNTS \_ \_ \_ \_ \_

This machine is equipped with strap cycle counter, furthermore it is allowed to be reset on this counter.

➤ How to reset counter?

In the Counter Page, press Potentiometer, then it will show as below to enter password (same as SERVICE MODE password), press Potentiometer to confirm.

Then it will show RESET, please rotate and press Potentiometer to confirm.

COUNTER

PASSWORD: \_ \_ \_ \_ \_

COUNTER

RESET NO/YES

## 5. ADJUSTMENT

### 5.1 Strap amount in the Pool Box

The recommended strap amount in Pool Box will be 2 of full arch size, it will be sufficient for 3-5 strap cycles. (Depend on package size, fewer cycles for larger package size)

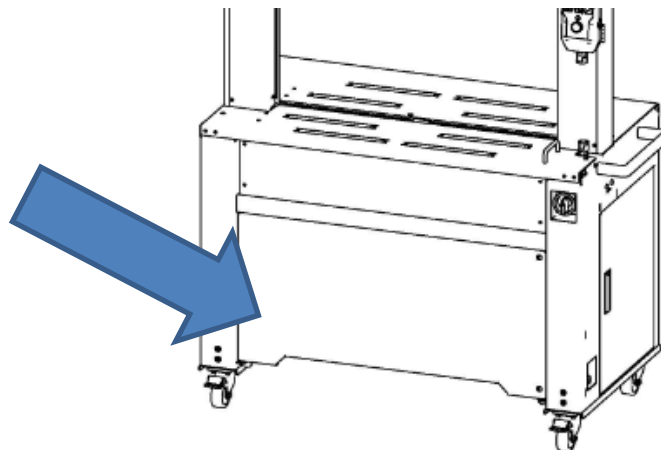
**Note: Excessive strap amount stored in Pool Box will cause feed problem (too curved)**

**Note: Insufficient strap amount stored in Pool Box will cause short feed**

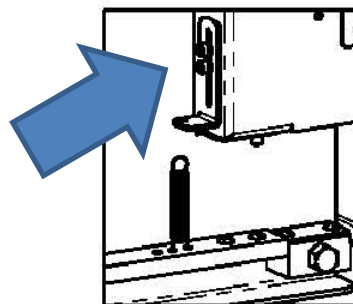
**Note: Strap stored in Pool Box overnight will make itself too curved and have chance to cause feed problem.**

The adjustment of strap amount of Pool Box as following:

- a. Open the front door



- b. Loose two screws for spring bracket, lifting upward for stronger spring force with more strap amount, vice versa



- c. Adjust to proper position on the spring bracket, then tight the screw

## 5.2 Pool Feed pressure & gap

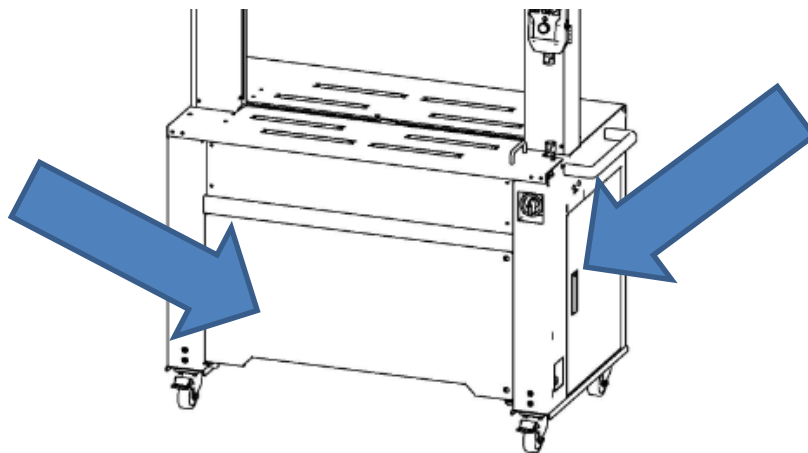
The machine is well set for the Pool Feed pressure and gap. It might need some adjustment when you have smooth strap on this machine.

**Note: Excessive pressure for Pool Feed Roller might cause strap squeezed then jammed**

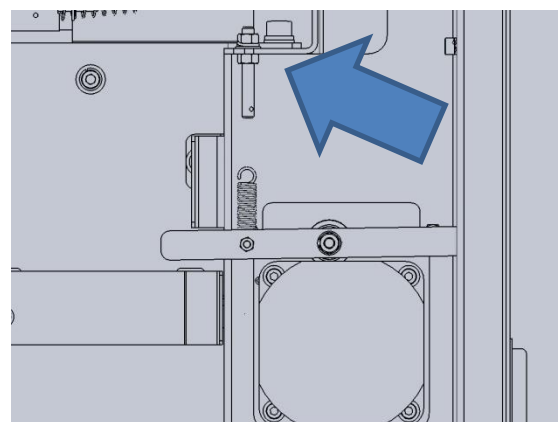
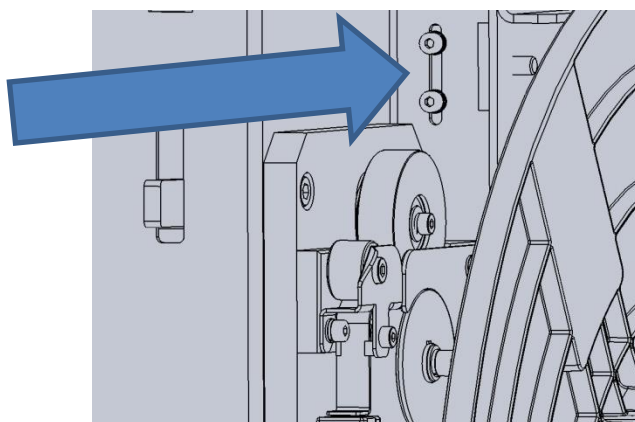
**Note: Insufficient pressure for Pool Feed Roller might cause insufficient strap amount in Pool Box.**

The adjustment of Pool Feed pressure and gap as following:

- a. Open the front door and side door



- b. Two screws from the side door could adjust the limit plate to control gap between Pool Feed Rollers, the suggested setting is 0.1mm for the gap. Then from the front door, there's one spring with nut to adjust pressure between Pool Feed Rollers.



### 5.3 Feeding / Refeeding pressure & gap

The machine is well set for Feeding/Refeeding pressure and gap. It might needs some adjustment when you have smooth strap or different thickness on this machine, to avoid short feed or feed jam issue happened.

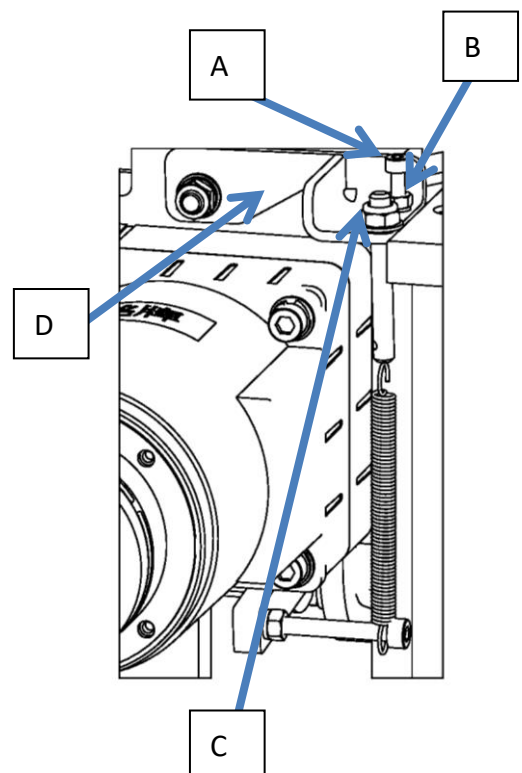
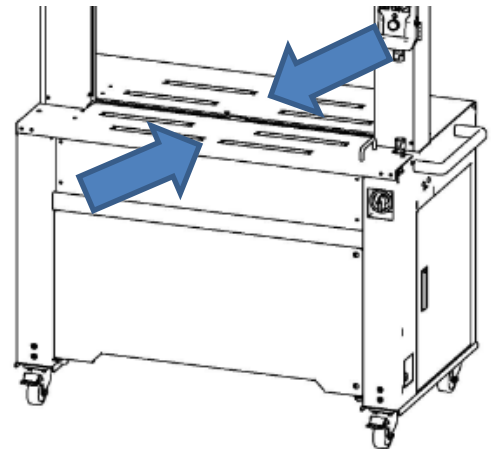
**Note: Excessive or insufficient gap between Feed Rollers might cause failure for auto threading and 2<sup>nd</sup> try feeding**

**Note: Excessive pressure for Feed Rollers might cause Z shape in bandways**

**Note: Insufficient pressure for Feed Rollers might cause short feed**

The adjustment of pressure and gap of Feed Rollers

- a. Open front and rear table cover
- b. Remove strap out from the Feed Rollers
- c. Adjust screw (A) for gap, to make sure driving and driven rollers slightly touched, then move outward for two turns on screw, and then lock the nuts (B) to fix the adjustment.
- d. Adjust nut (C) for pressure, to make sure the spring force is able to hold the lever (D) downward



## 5.4 Tension

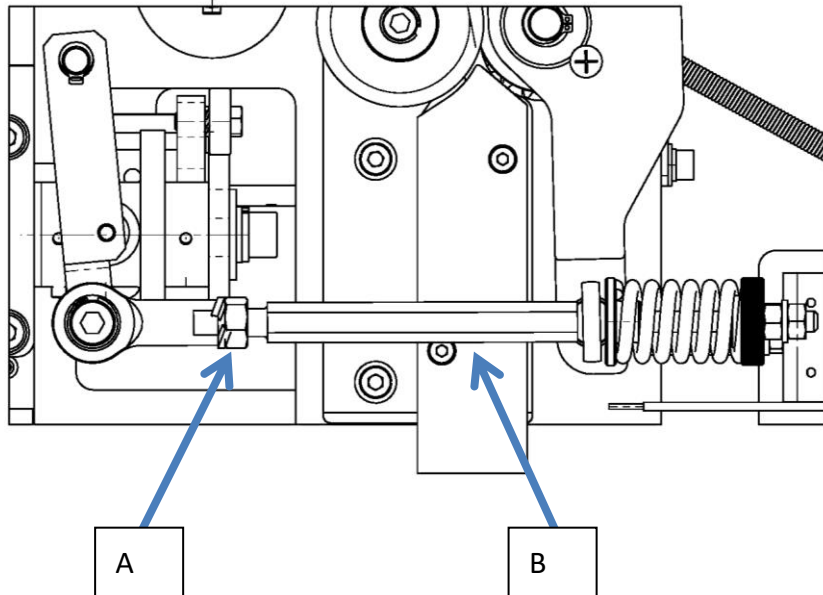
The machine is well set for Tension. It might needs some adjustment when you have smooth strap or different thickness on this machine, or you have different application.

**Note: Excessive Tension might cause damage on strap then jammed**

**Note: Excessive Tension might also cause Tension Roller touch strap in zero position then having Feeding or Refeeding problem.**

The adjustment of Tension:

- a. Open front and rear table cover
- b. Make sure with strap between Tension Rollers
- c. Use LCD function "SERVICE MODE" and manual run CAM to Tension Position
- d. Release nut (A) and adjust the rod (B)



- e. When the Tension Roller slightly grabs the strap, then adjust the rod for 1 full turn, then lock the nut to fix the adjustment
- f. Use LCD function "SERVICE MODE" and manual run CAM back to Zero Position



## 5.5 Brush in Arch

The machine is well set for Brush in Arch to avoid strap floating or flipping.

**Note: Brush in Arch may need some adjustment for special package shape or different application/different strap width.**

The adjustment of Brush:

Release screws to adjust brush

➤ Left:

Left Upper: Brush slight touch width of strap

Left Lower: Brush covers 1/3 width of strap

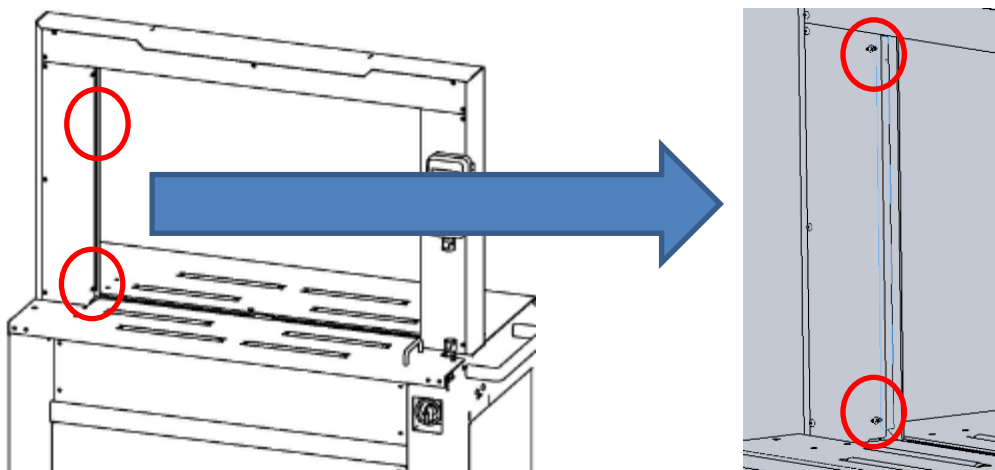
➤ Upper:

Complete open

➤ Right:

Right Upper: Brush covers 2/3 width of strap

Right Lower: complete close



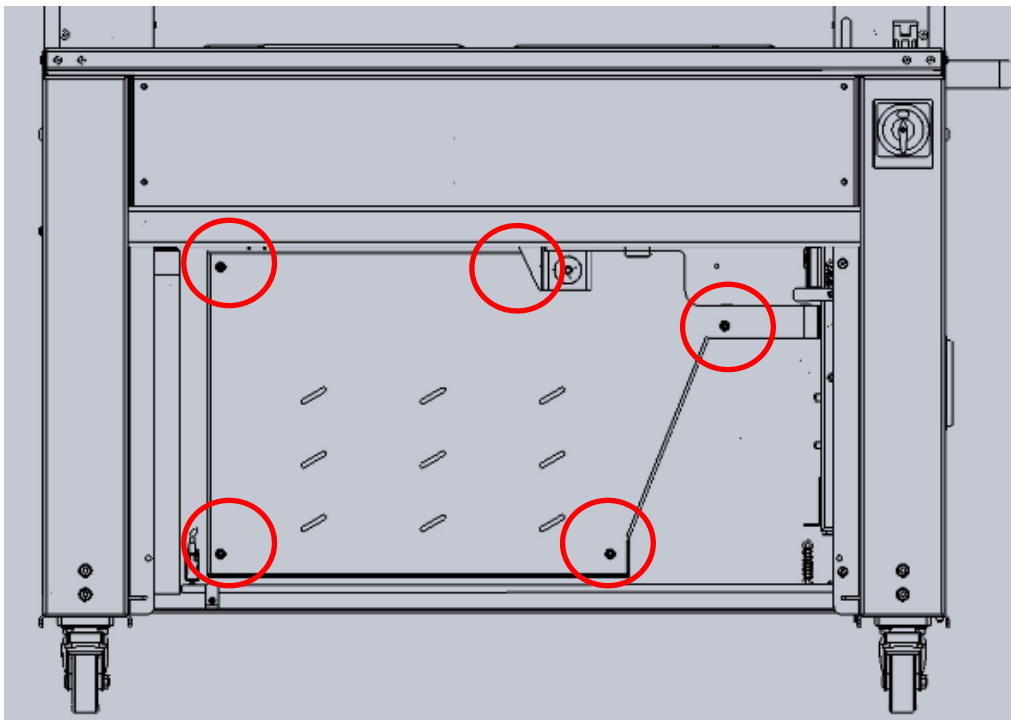
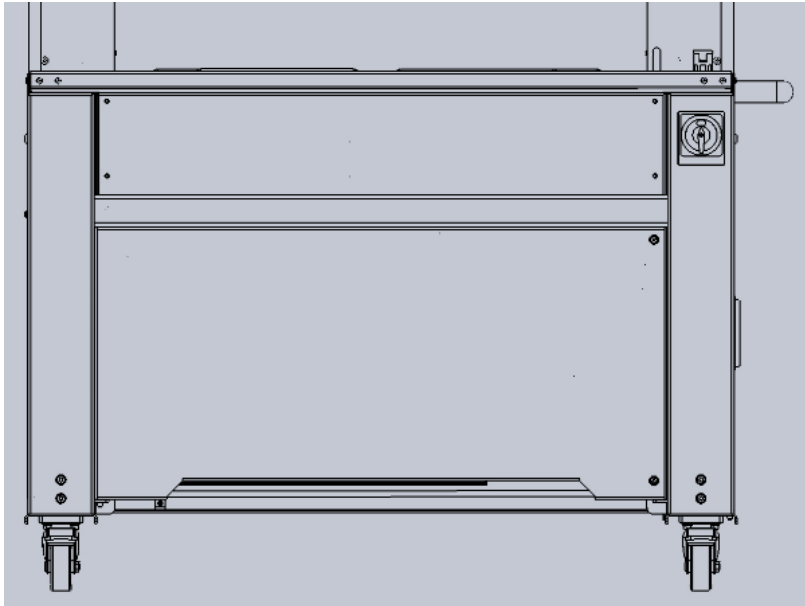
## 5.6 Change between 9mm and 12mm

The machine is able to change between 9mm and 12mm strap only adjustment.

### Note: Tools Needed

Change between 9mm and 12mm:

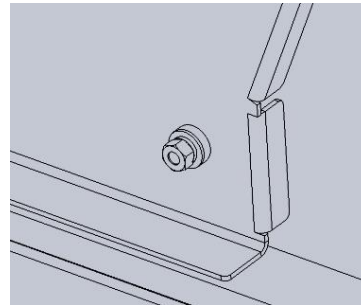
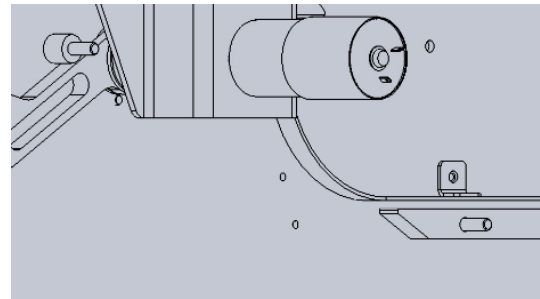
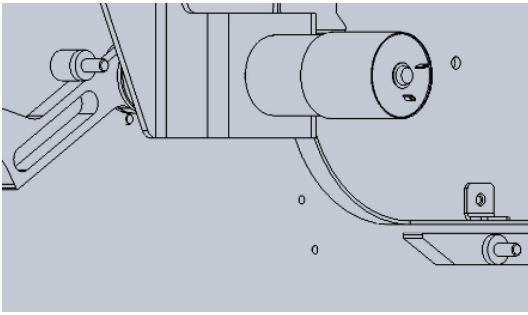
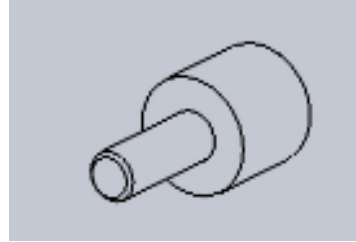
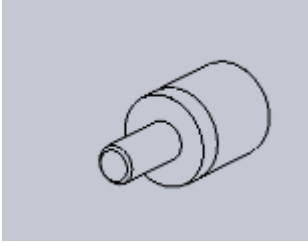
- a. Open front door and remove 5 nuts to take off the Pool Box Cover



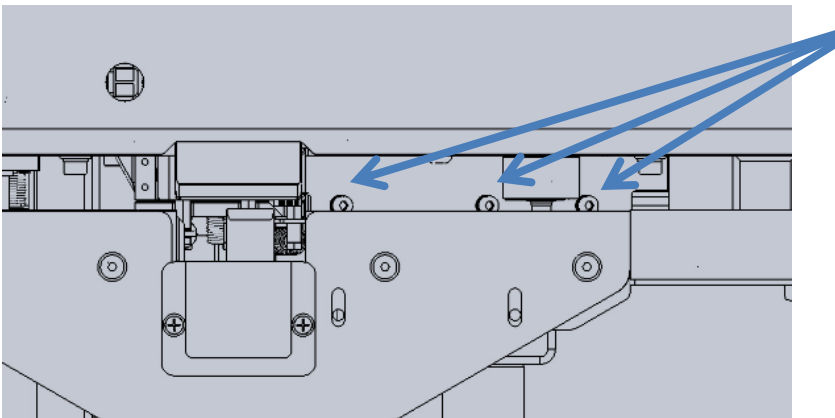
b. Put necessary spacer in the Pool Area:

Long spacer + short spacer = 12mm application

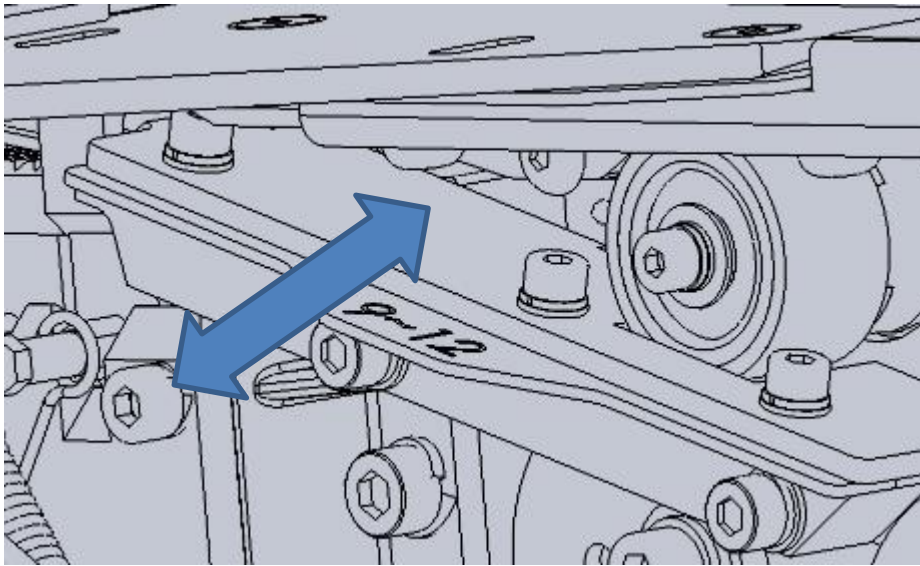
Long Spacer = 9mm application (remember to fix the short spacer outside in case it's missing)



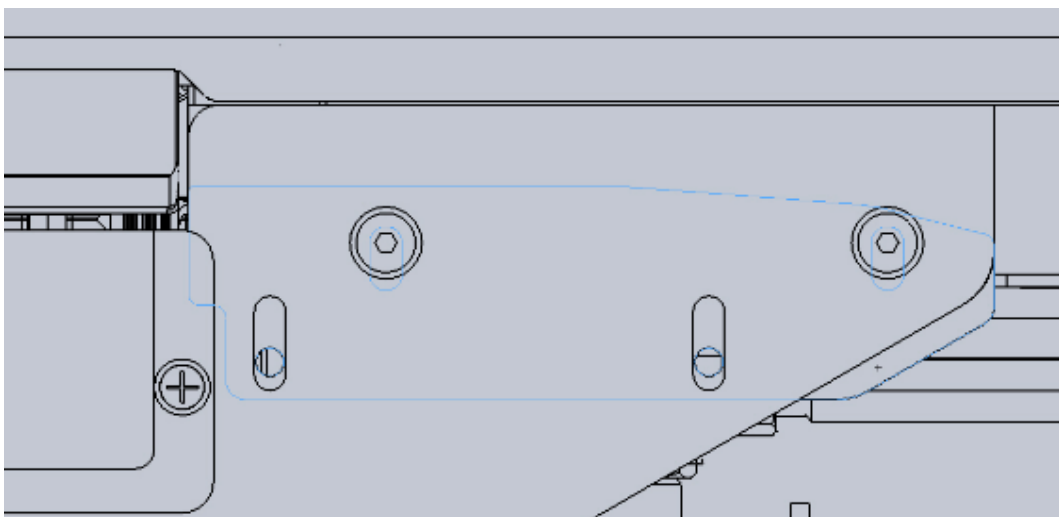
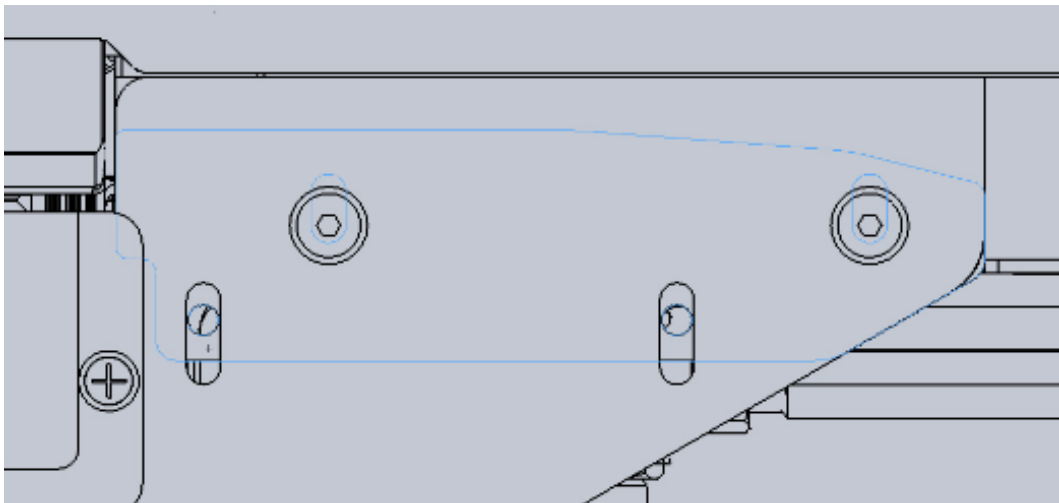
c. Open the arch and release 3 screws for Feeding Bandway



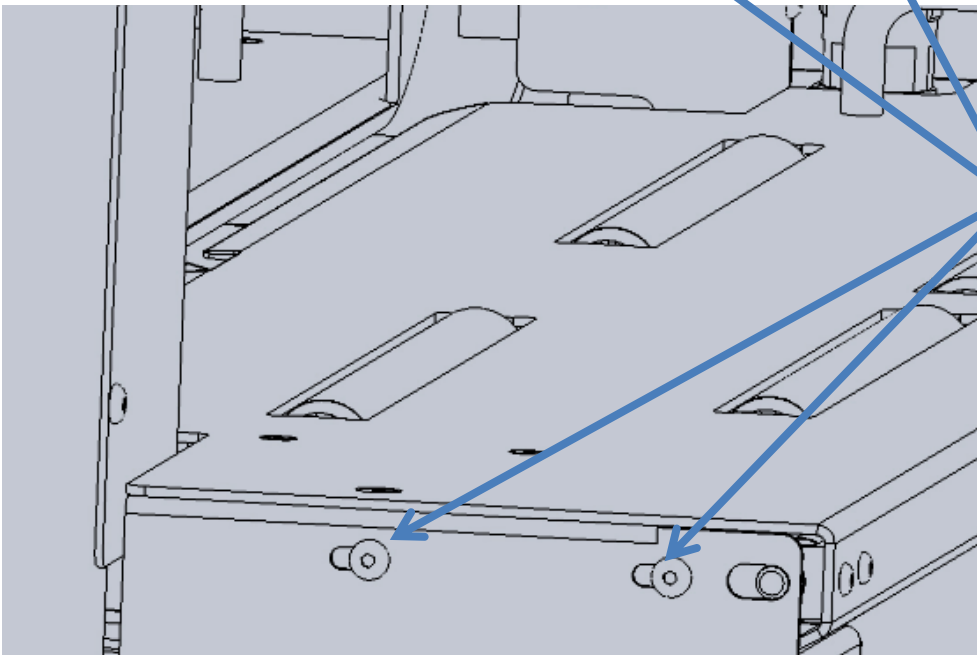
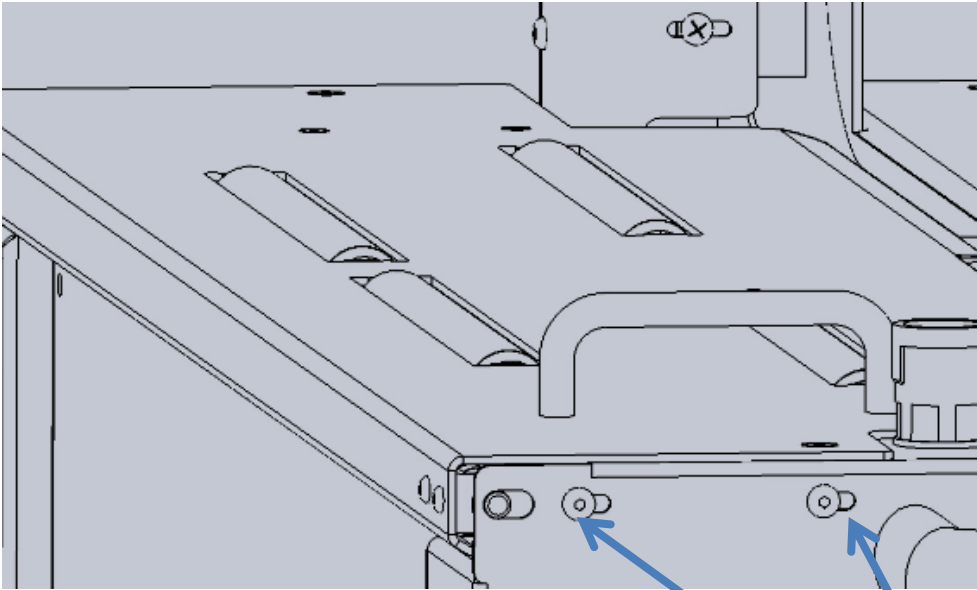
- d. Adjust the plate to touch strap then pulling outward about 1mm more



- e. Adjust the Arch Bandway Right to touch strap then pulling outward about 1mm more



- f. Adjust front table cover, there are two screws on each side, loose the screws then move front table forward or backward to fit with strap, then pulling out around 0.5mm more.



- g. Adjust brush, follow instruction in EXS-158 PLUS operation manual 5.5 **Brush in Arch**

## 6. TROUBLE SHOOTING

Error List:

LCD Display will show error situation for this machine, at the same time technician could open the electric box check LED lights on main PCB in detail.

➤ **ERROR (M313), LCD FAIL (J6)**

It means there's no signal between LCD panel board and main PCB. Please check the connection/wiring is good and tight, or replace new LCD panel board.

➤ **ERROR (M302), MOTOR ISSUE**

It means PCB drives CAM motor over 3 seconds but no signal back to PCB. Please go to service mode to manually drive CAM motor, if it runs continuously without any stop, it means the position limit switch (approx. sensor) is failing. If the motor can't run in service mode, please check CAM motor cable connection or replace new CAM motor.

➤ **ERROR (M305), AUTO THREAD FAIL**

It means auto threading is fail.

- Please go to service mode to manually run auto thread motor if it's normal, if it's not running, please check cable connection or decrease pressure for auto thread arm.
- Please make sure the auto thread arm should keep close when pool feed motor runs strap into feeding roller. If not, please increase pressure for auto thread arm.
- Please make sure the auto thread arm should keep open after strap is arrived feeding roller. If not, please increase pressure for auto thread arm.
- Please make sure feed roller are in good adjustment for gap (please follow operation manual 5.3 **Feeding / Refeeding pressure & gap**)
- Please make sure all strap guiding are in proper adjustment, if the adjustment is too tight, it could catch the strap from feeding.
- Please make sure the actuator working normally.

➤ **ERROR (M306), LOW STRAP**

It means pool feed runs overtime but still insufficient strap in pool box. Please check if the Pool Feed structure is clean and Pool Feed motor works normally.

➤ **ERROR (M307), SHORT FEED**

It means the machine already feeds in maximum time but still not able to arrive the actuator.

- Please make sure strap in Pool Box is not curved too much
- Please make sure Feed Roller are in good gap and pressure adjustment (please follow operation manual 5.3 **Feeding / Refeeding pressure & gap**)
- Please make sure all strap guiding are in proper adjustment, if the adjustment is too tight, it could catch the strap from feeding.
- Please make sure the actuator working normally.
- Please make sure the arch is complete close when in zero position. You are able to pull the arch open arm for open the arch and the arch will be close, when release the open arm.

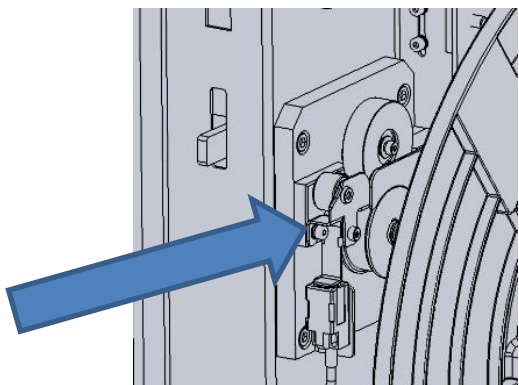
## 7. MAINTENANCE

Note: Before doing any maintenance or service, please do switch off the main power on the machine, then wait about 5 minutes to cool down the heater plate.

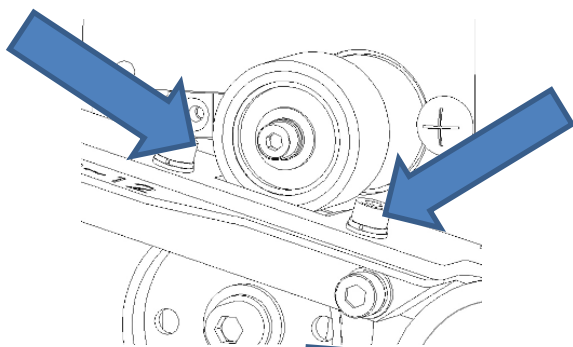
### Weekly Maintenance:

- Use air gun to clean dust from the machine, especially following clean dust from following structures:

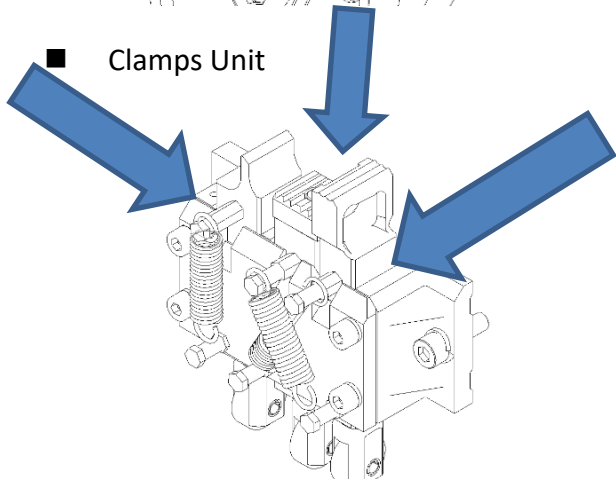
- Pool Feed Unit



- Feed Roller Unit

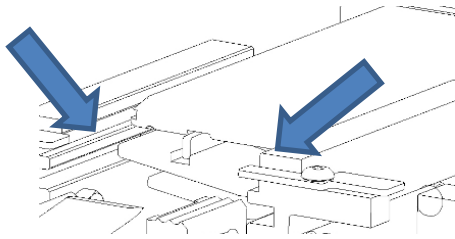


- Clamps Unit



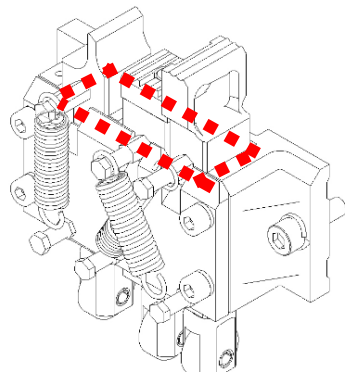


■ Sliding table Unit & Separator Unit

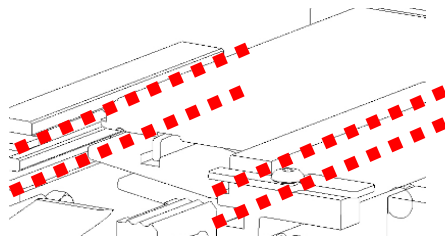


➤ Lubrication on moving mechanism , especially lubricate on following structures:

■ Clamps Unit



■ Sliding table Unit & Separator Unit



**Note: Do not lubricate on any bandway or guide where transport strap.**

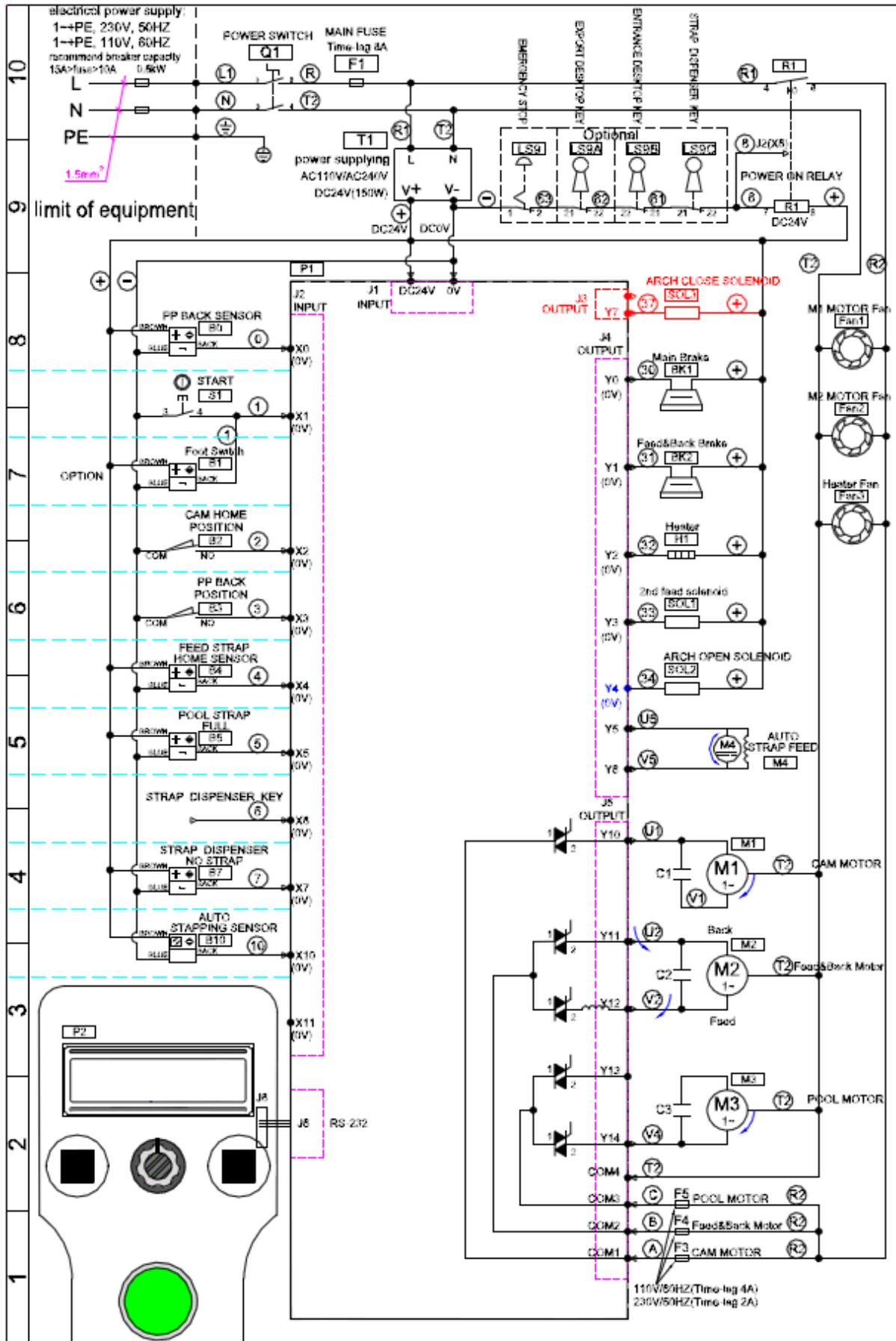
**Monthly Maintenance:**

- Please take out END GRIPPER UNIT and WELDING CLAMP UNIT to do complete cleaning and lubrication
- Please clean both sides (upper/lower) of Heater Plate
- Please check all structure with spring if working smoothly
- Please clean dust around sensor, limit switch
- Please clean dust accumulated on rollers (Pool Feed Roller, Tension Roller, Feed Roller)

# 8. ELECTRIC WIRING DIAGRAM & PART



C	PART NO.	DESCRIPTION	Q'TY
T1	P0307-010001600	POWER SUPPLY	1
R1	P0306-020000100	RELAY	1
	P0306-030000100	RELAY SEAT	1
	P0316-050000100	RELAY FIX PLATE	2
P1	P0309-01001090B	MAIN BOARD	1
F1	P0305-030001100	FUSE 8A	1
	P0305-020001000	FUSE SEAT	1
	P0305-020001100	FUSE COVER	1
F3,4,5	P0305-030000100	FUSE 2A (For 220V)	3
	P0305-030001000	FUSE 4A (For 110V)	3
	P0305-020001000	FUSE SEAT	3
	P0305-020001100	FUSE COVER	3
C1,C2	P0318-040002300	Motor capacitance (For 220-240V)	2
	P0318-040000700	Motor capacitance (For 110V)	2
C3	P0318-040000800	Motor capacitance (For 220-240V)	1
	P0318-040000700	Motor capacitance (For 110V)	1
X0	P0304-010001800	TERMINAL SEAT 31P	1
X1	P0304-010005600	TERMINAL SEAT 12P	1



## 9. PART LIST

**FIG. 1-1 CASTER UNIT**

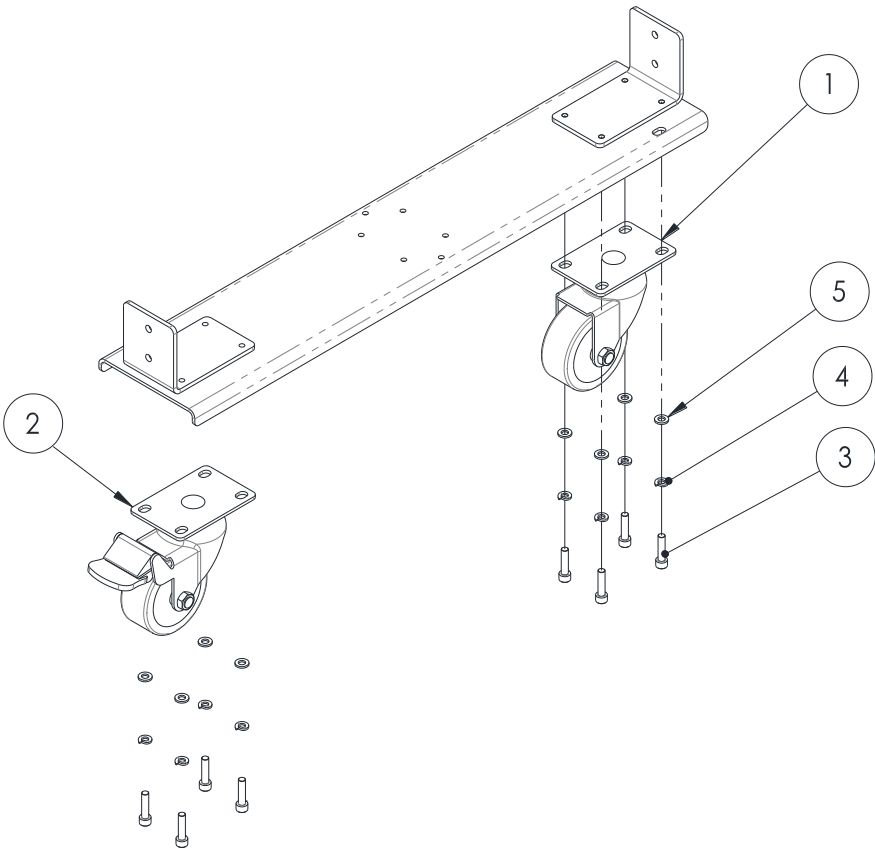
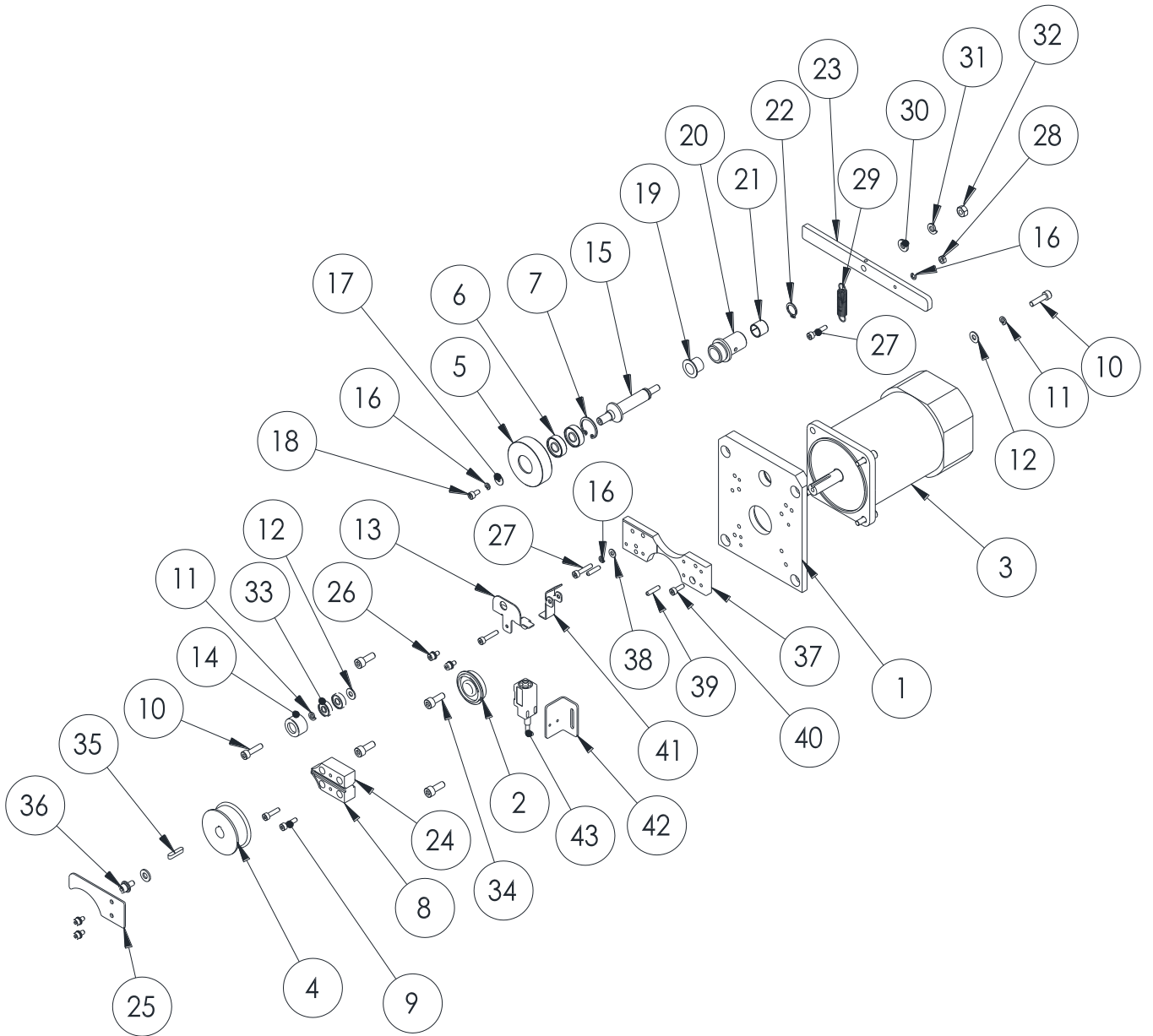


FIGURE 1-1 CASTER UNIT			
NO	PART NUMBER	Description	QTY
1	P1107-0004500	CASTER	1
2	P1107-0004600	CASTER WITH BRAKE	1
3	P1101-0506025AN	SCREW M6*25L	8
4	P1103-0206Z	SPRING WASHER φ6	8
5	P1103-010612N	WASER φ6*12*1t	8

**FIG. 2-1 POOL FEED UNIT**

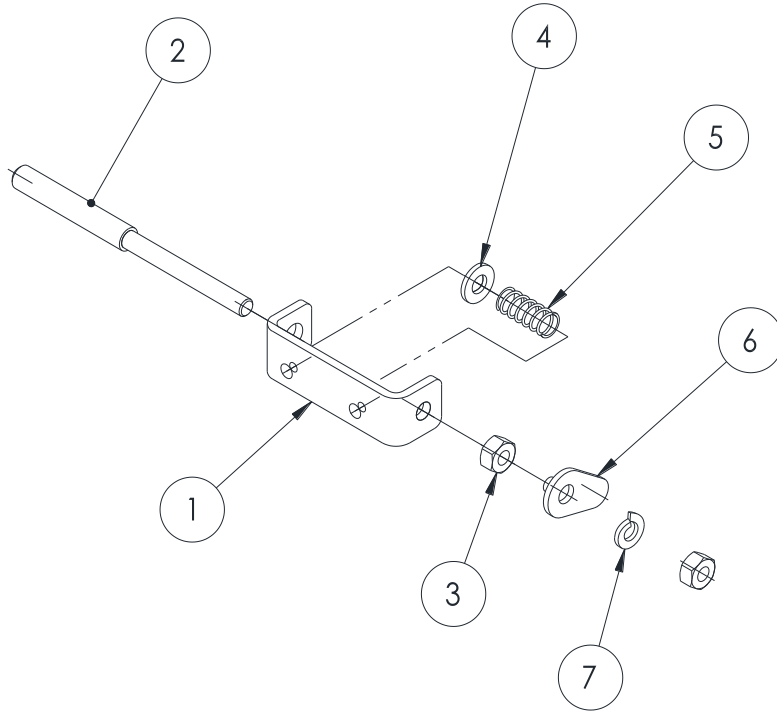




<b>FIGURE 2-1 POOL FEED UNIT</b>			
<b>NO</b>	<b>PART NUMBER</b>	<b>Description</b>	<b>QTY</b>
1	P02-033970B	POOL FEED SEAT	1
2	P1104-076201ZZ0	BEARING	1
3	P0501-0018300	POOL MOTOR 220V	1
	P0501-0018400	POOL MOTOR 110V	1
4	P02-0340400	POOL FEED DRIVING ROLLER	1
5	P02-034030A	POOL FEED DRIVEN ROLLER	1
6	P1104-020608ZZ1	BEARING	2
7	P1105-0222B	C-RING, R-22	1
8	P02-0340100	POOL FEED LOWER GUIDE 9-12mm	1
9	P1101-0504016AN	SCREW M4*16	2
10	P1101-0505020AN	SCREW M5*20	5
11	P1103-0205Z	SPRING WASHER $\phi$ 5	5
12	P1103-010512N	WASHER $\phi$ 5*12	5
13	P01-055600A	THREADING SEAT	1
14	P02-034120A	GUIDE ROLLER	1
15	P02-0340200	POOL FEED ECCENTRIC SHAFT	1
16	P1103-0204Z	SPRING WASHER $\phi$ 4	3
17	P1103-010412N	WASHER $\phi$ 4*12	1
18	P1101-0504008AN	SCREW M4*8	1
19	P1104-0312122	BEARING	1
20	P02-0339900	POOL FEED BUSHING	1
21	P1104-0312120	BEARING	1
22	P1105-0112B	C-RING, S-12	1
23	P01-0555800	LIFTING LEVER	1
24	P02-0340000	POOL FEED UPPER GUIDE 9-12mm	1
25	P01-0555900	POOL FEED FRONT GUIDE	1
26	P1101-0904008AN	SCREW M4*8	4
27	P1101-0504020AN	SCREW M4*20	3
28	P1102-0104AZ	NUT M4	1
29	P1202-0001000	SPRING	1
30	P1103-010613N	WASHER $\phi$ 6*13	2
31	P1103-0206Z	SPRING WASHER $\phi$ 6	5

<b>FIGURE 2-1 POOL FEED UNIT</b>			
<b>NO</b>	<b>PART NUMBER</b>	<b>Description</b>	<b>QTY</b>
32	P1102-0106AN	NUT M6	1
33	P1104-020625ZZ0	BEARING, 625ZZ	2
34	P1101-0506016AN	SCREW M6*16	4
35	P1108-010404020G	KEY 4*4*20	1
36	P1101-0905012AN	SCREW M5*12	1
37	P02-0339810	POOL SPACER 9-12mm	1
38	P1103-010409N	WASHER $\psi$ 4*9	1
39	P1109-0204018G	PIN 4*18	2
40	P1101-0504012AN	SCREW M4*12	1
41	P01-0558600	DETECTION PLATE	1
42	P01-0555600	DETECTION PLATE FIXER	1
43	P0319-S15835	PROX SWITCH (3METER)	1

**FIG. 3-1 TABLE PIN UNIT**



<b>FIGURE 3-1 TABLE PIN UNIT</b>			
<b>NO</b>	<b>PART NUMBER</b>	<b>Description</b>	<b>QTY</b>
1	P01-0550100	PIN SEAT	1
2	P02-0349100	TABLE PIN	1
3	P1102-0106AN	NUT M6	2
4	P1103-010613N	WASHER φ6*13	2
5	P1201-0000200	SPRING	1
6	P01-0585200	PICK	1
7	P1103-0206Z	SPRING WASHER φ6	1

**FIG. 4-1 FRONT TABLE UNIT**

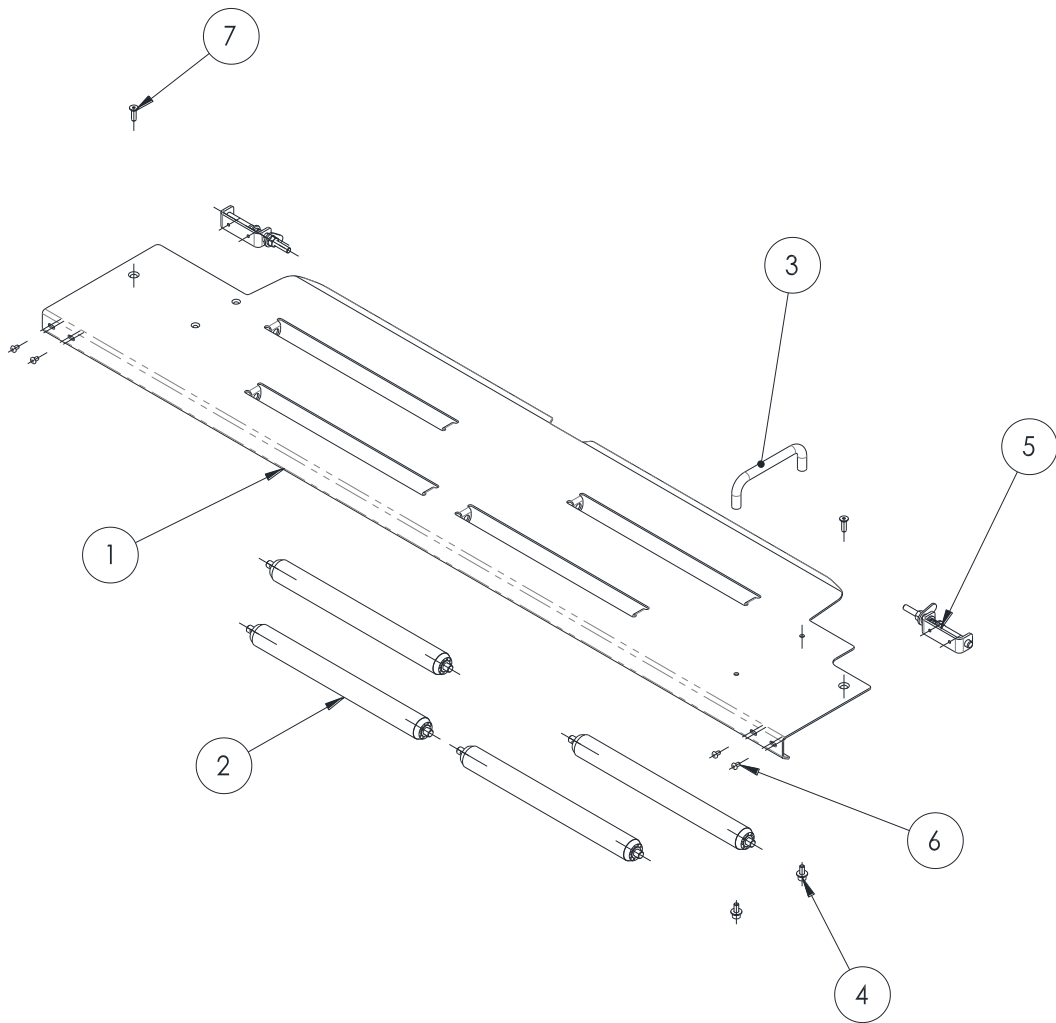


FIGURE 4-1 FRONT TABLE UNIT			
NO	PART NUMBER	Description	QTY
1	P01-054762A	FRONT TABLE COVER	1
2	P08-0002800	TABLE ROLLER	4
3	P1112-0002900	TABLE HANDLE	1
4	P1101-0905012AN	SCREW M5*12	2
5		TABLE PIN UNIT – FIG 3-1	2
6	P1101-0604006AN	SCREW M4*6	4
7	P1101-0405016AN	SCREW M5*16	2

**FIG. 5-1 REAR TABLE UNIT**

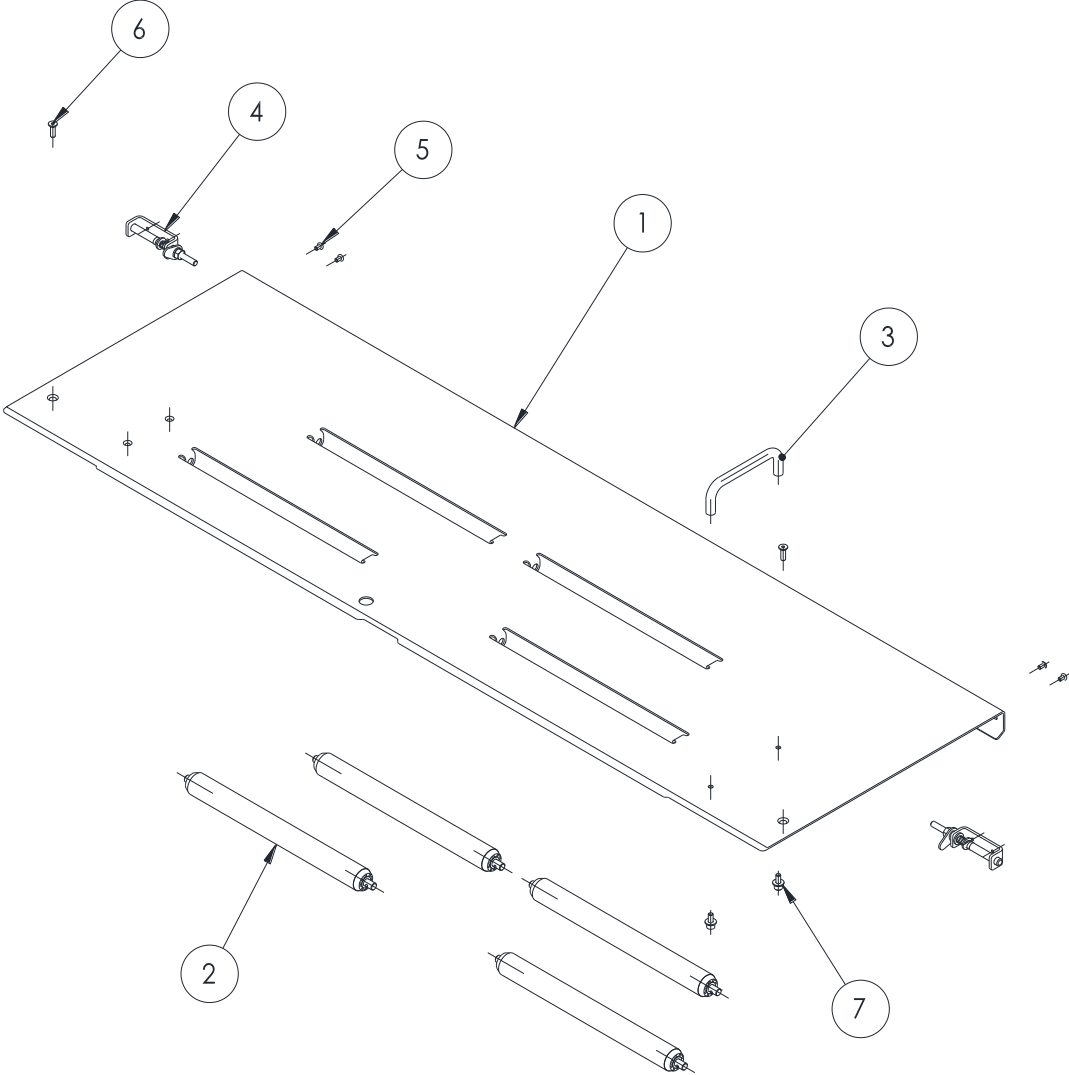
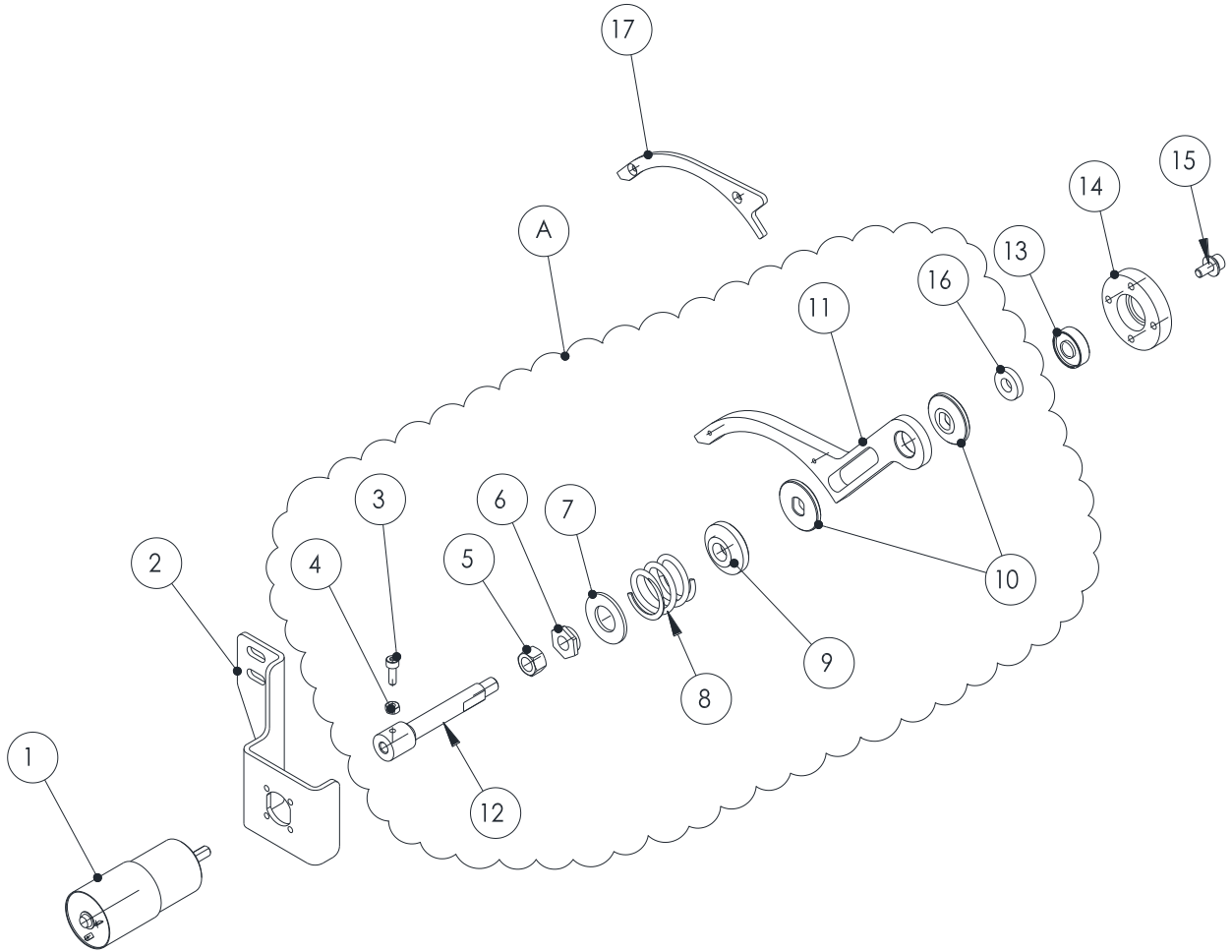


FIGURE 5-1 REAR TABLE UNIT			
NO	PART NUMBER	Description	QTY
1	P01-054772A	REAR TABLE COVER	1
2	P08-0002800	TABLE ROLLER	4
3	P1112-0002900	TABLE HANDLE	1
4		TABLE PIN UNIT – FIG 3-1	2
5	P1101-0604006AN	SCREW M4*6	4
6	P1101-0405016AN	SCREW M5*16	2
7	P1101-0905012AN	SCREW M5*12	2

**FIG. 6-1 AUTO THREADING UNIT**



<b>FIGURE 6-1 AUTO THREADING UNIT</b>			
<b>NO</b>	<b>PART NUMBER</b>	<b>Description</b>	<b>QTY</b>
A	P02-0363100	AUTO FEED GUIDE ASSEM	1
1	P0501-0018500	AUTO THREAD MOTOR	1
2	P01-0552900	AUTO THREAD MOTOR BRACKET	1
3	P1101-0504012AN	SCREW M4*12	1
4	P1102-0104AN	NUT, M4	1
5	P1102-0110AZ	NUT, M10	1
6	P02-0372600	ADJUST RING	1
7	P01-0553000	FIXED RING	1
8	P1201-0010900	AUTO THREADING SPRING	1
9	P02-0340900	ADJUSTING FIXER	1
10	P06-0064800	FRICTION PLATE	2
11	P02-034080A	AUTO FEED GUIDE	1
12	P02-0372400	AUTO FEED SHAFT	1
13	P1104-020608ZZO	BEARING	1
14	P02-0340600	BEARING SEAT	1
15	P1101-0905012AN	SCREW M5*12L	1
16	P02-0372500	SUPPORT RING	1
17	P01-0607200	SPACER 15MM	1

**FIG. 7-1 POOL GUIDE ROLLER UNIT**

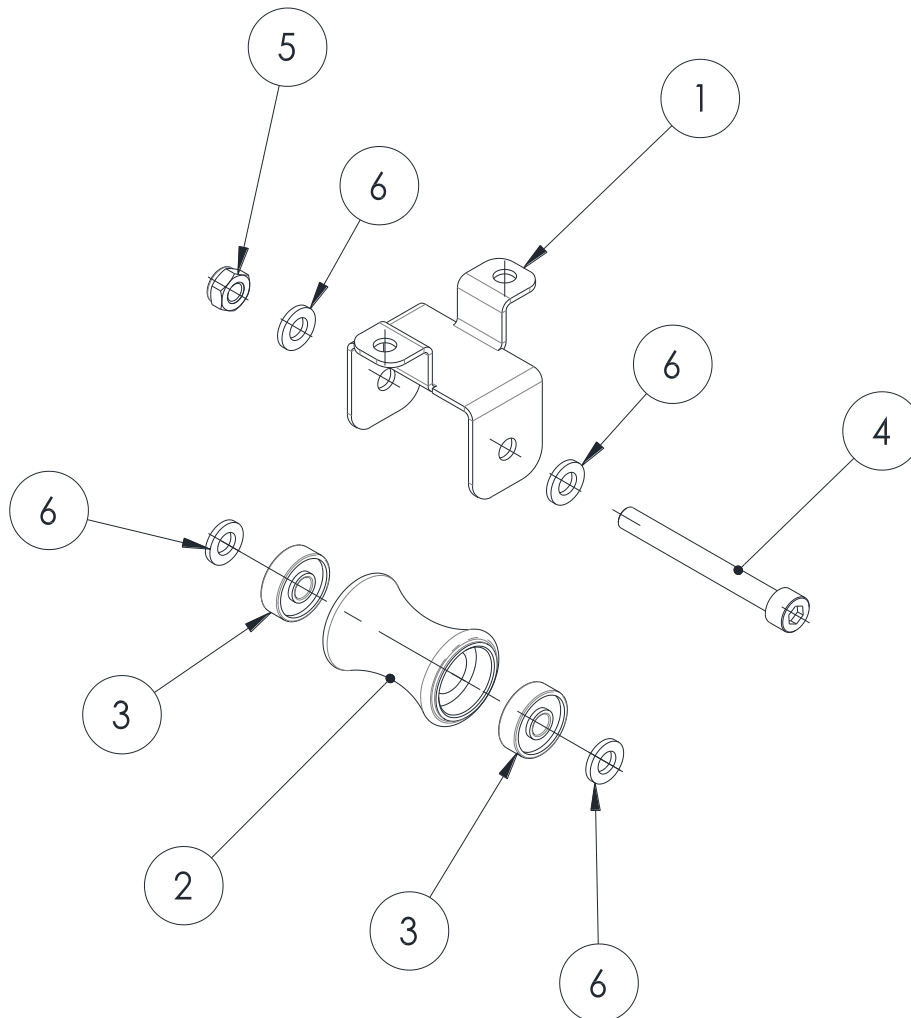
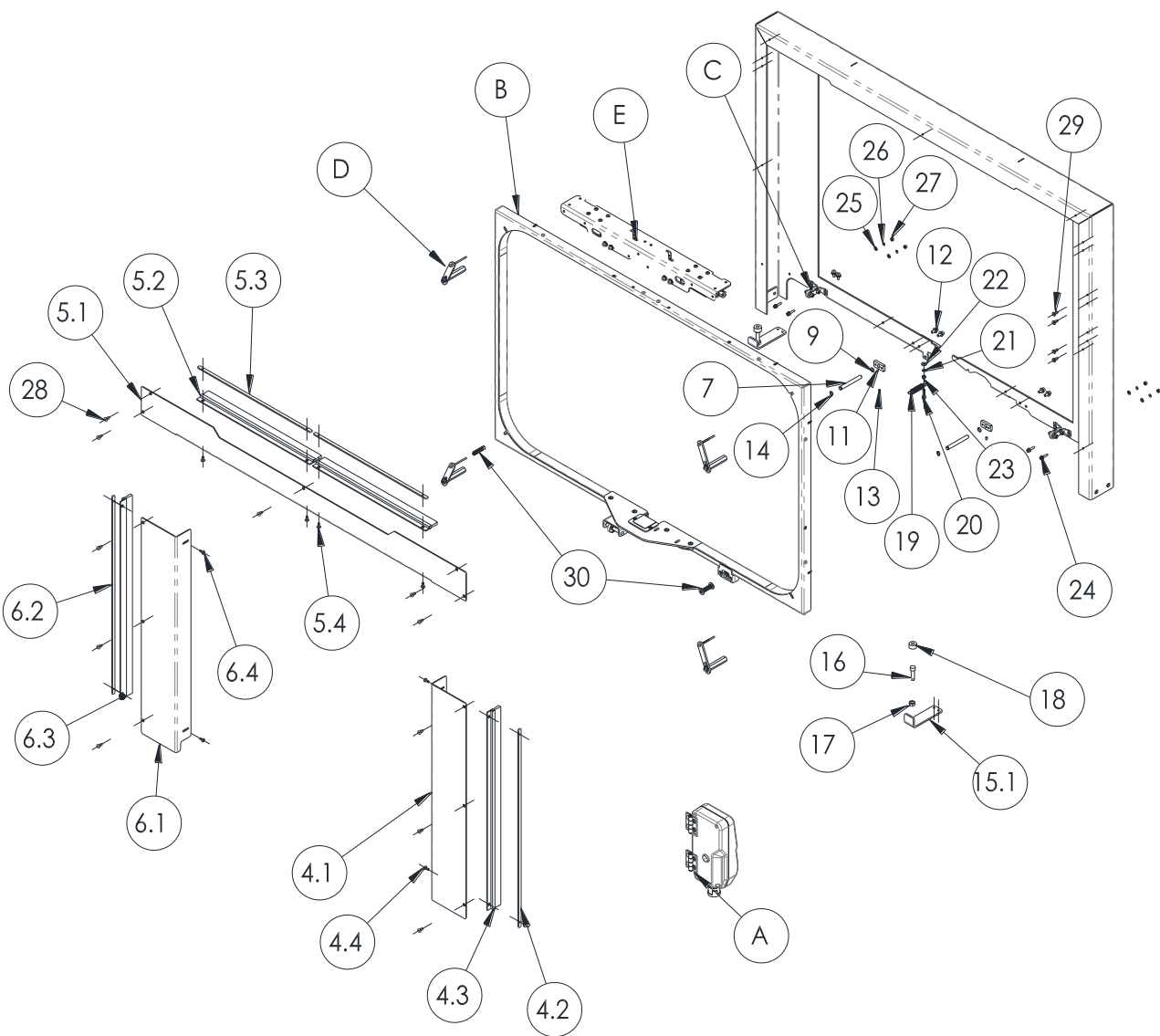


FIGURE 7-1 POOL GUIDE ROLLER UNIT			
NO	PART NUMBER	Description	QTY
1	P01-0552800	POOL GUIDE ROLLER BRACKET	1
2	P02-0341600	POOL GUIDE ROLLER	1
3	P1104-020626ZZ0	BEARING, 626ZZ	2
4	P1101-0506055AN	SCREW M4*12	1
5	P1102-0106BZ	NUT, M6	1
6	P1103-010612N	WASHER, $\phi 6*12*1t$	4



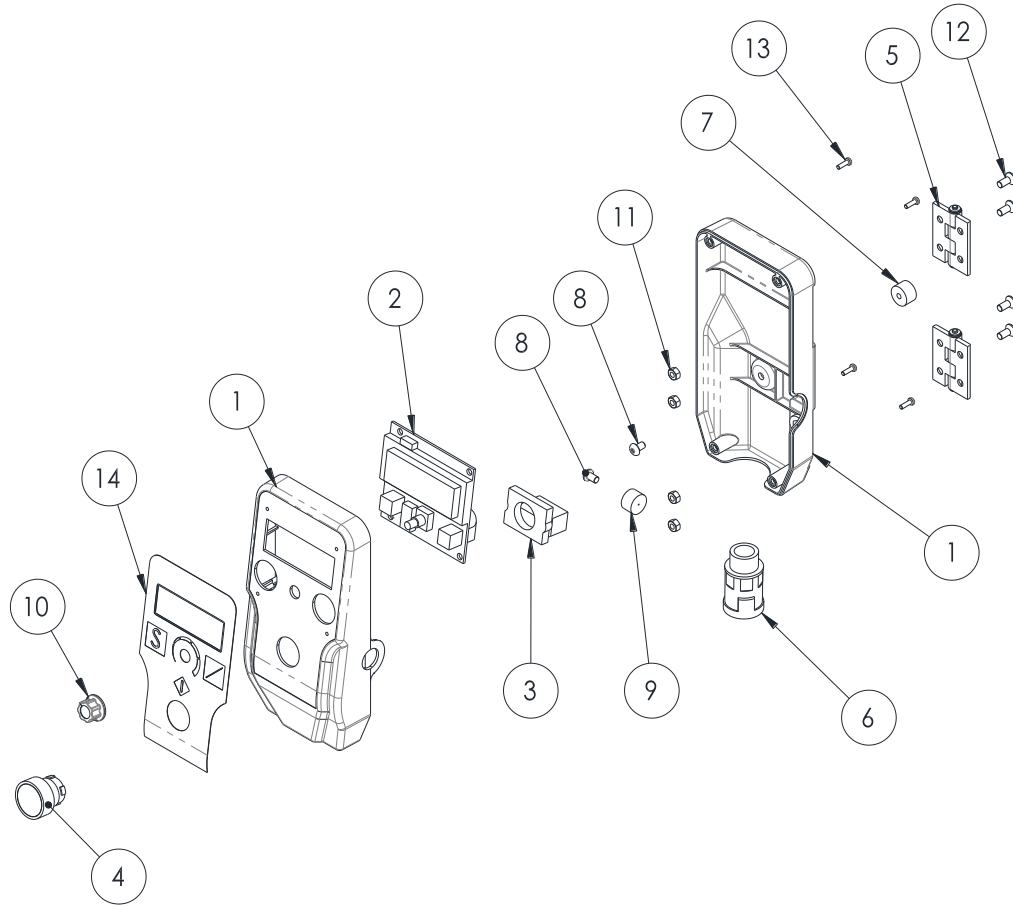
FIG. 8-1 ARCH UNIT



<b>FIGURE 8-1 ARCH UNIT</b>			
<b>NO</b>	<b>PART NUMBER</b>	<b>Description</b>	<b>QTY</b>
A		CONTROL BOX UNIT – FIG 9-1	1
B		ARCH (850*600MM)	1
C		ARCH SUPPORT UNIT – FIG 11-1	2
D		EJECT PIN UNIT – FIG 12-1	4
E		UPPER ARCH OPEN UNIT FIG 31-1	1
4.1	P01-054712A	ARCH COVER (RIGHT)	1
4.2	P01-0549620	BRUSH FIX PLATE (RIGHT)	1
4.3	P13-0001100	BRUSH (RIGHT)	1
4.4	P1101-0104010AZ	SCREW M4*10	2
5.1	P01-054732A	ARCH COVER (UPPER)	1
5.2	P13-0000900	BRUSH (UPPER)	2
5.3	P01-0549600	BRUSH FIX PLATE (UPPER)	2
5.4	P1101-0104010AZ	SCREW M4*10	4
6.1	P01-054722A	ARCH COVER (LEFT)	1
6.2	P01-0549620	BRUSH FIX PLATE (LEFT)	1
6.3	P13-0001100	BRUSH (LEFT)	1
6.4	P1101-0104010AZ	SCREW M4*10	2
7	P02-033870A	ARCH GUIDE SHAFT	2
9	P1116-P0080	O RING	2
11	P02-0338900	ARCH GUIDE SEAT	2
12	P1101-0905012AN	SCREW M5*12	6
13	P1101-0704006AB	SCREW M4*6	2
14	P1105-0108B	C-RING S-8	2
15	P01-0554800	ARCH ADJUST PLATE	1
16	P1101-0508025AN	SCREW M8*25	1
17	P1102-0108AZ	HEX NUT, M8	1
18	P06-006500A	CUSHION M8	1
19	P1202-0007300	SPRING	1
20	P1101-0505020AN	SCREW M5*20	1
21	P1103-0205Z	SPRING WASHER $\phi$ 5	1
22	P1103-010512N	WASHER $\phi$ 5*12	1
23	P1102-0105AN	HEX NUT, M5	1
24	P1101-0904018AN	SCREW M4*18	4

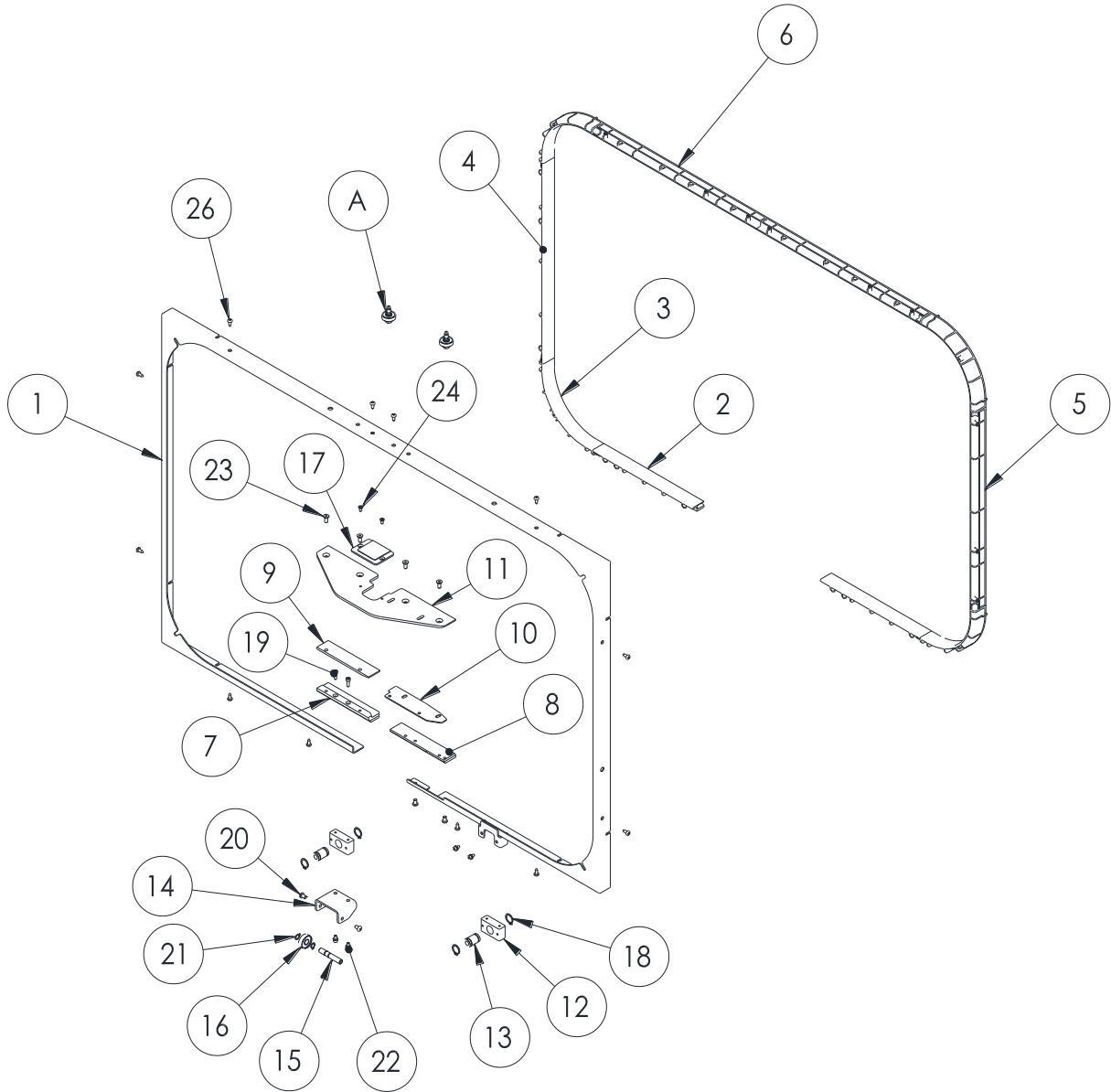
<b>PARTS LIST. FIGURE 8-1 ARCH UNIT</b>			
<b>NO</b>	<b>PART NUMBER</b>	<b>Description</b>	<b>QTY</b>
25	P1103-010409N	WASHER $\phi 4 \times 9$	4
26	P1103-0204Z	SPRING WASHER $\phi 5$	4
27	P1102-0104BZ	HEX NUT, M4	4
28	P1101-0605010AN	SCREW M5*10	11
29	P1101-0405012AN	SCREW M5*12	4
30	P1201-0011400	SPRING	2

**FIG. 9-1 CONTROL BOX UNIT**



<b>FIGURE 9-1 CONTROL BOX UNIT</b>			
<b>NO</b>	<b>PART NUMBER</b>	<b>Description</b>	<b>QTY</b>
1	P06-0063000	CONTROL BOX	1
2	<b>P0309-02000260A</b>	LCD BOARD	1
	<b>P0309-010014300</b>	<b>VR BOARD</b>	1
3	P0313-010005700	START BUTTON	1
4			
5	P1110-010000300	HINGE	2
6	P0401-0006000	CABLE CONNECT	1
7	P1106-020000100	REAR MAGNET	1
8	P1101-0605008AN	SCREW M4*10	2
9	P1106-020000800	SIDE MAGNET	1
10	<b>P1113-000100A</b>	KNOB RN-99F, § 6.4	1
11	P1102-0105AN	NUT, M5	4
12	P1101-0405012AN	SCREW M5*12	4
13	P1101-0303010AZ	SCREW M3*10	4
14	P1002-0009000	CONTROL BOX LABEL	1

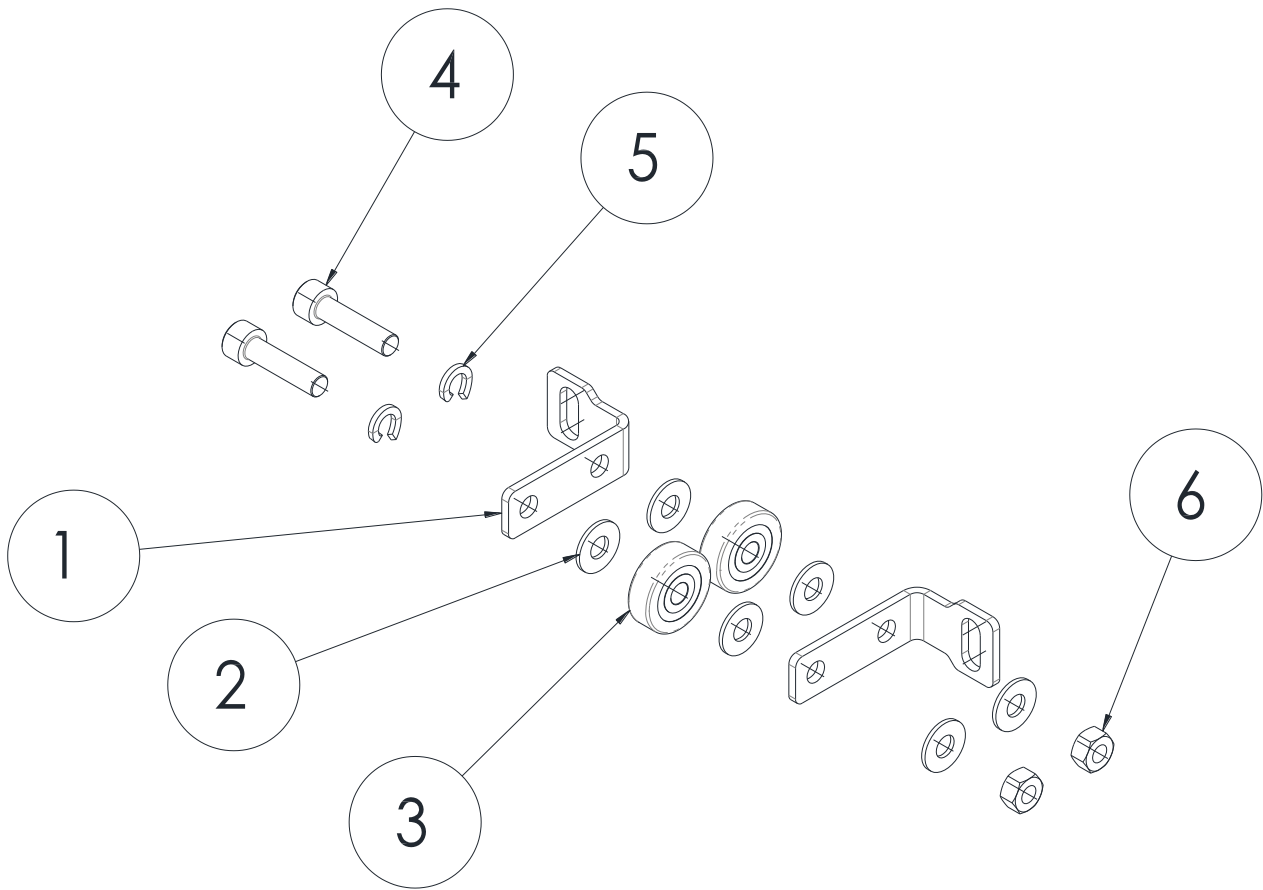
**FIG. 10-1**      **INNER ARCH UNIT**



**FIGURE 10-1 INNER ARCH UNIT**

<b>NO</b>	<b>PART NUMBER</b>	<b>Description</b>	<b>QTY</b>
1	P01-054751C	INNER ARCH BRACKET	1
2	P06-0064000	9~12MM BANDWAY	2
3	P06-0064300	9~12MM BANDWAY CORNER	4
4	P06-0064200	9~12MM BANDWAY	1
5	P06-0064240	9~12MM BANDWAY	1
6	P06-0064100	9~12MM BANDWAY	2
7	P02-0339100	BANDWAY CONNECTING GUIDE (L)	1
8	P02-033920A	BANDWAY CONNECTING GUIDE (R)	1
9	P01-0554400	ARCH LEFT GUIDE PLATE	1
10	P01-055450A	ARCH RIGHT ADJUSTING PLATE	1
11	P01-055460B	ARCH BRIDGE	1
12	P02-033880A	ARCH GUIDE SEAT	2
13	P1104-01082	LINEAR BEARING	2
14	P01-0556200	ARCH OPENING BRACKET	1
15	P02-0339000	SHAFT	1
16	P1104-020628ZZ0	BEARING 628ZZ	1
17	P01-055470B	HEATER PLATE COVER	1
18	P1105-0115B	C RING S-15	4
19	P1101-0504012AN	SCREW M4*12	2
20	P1101-0605008AN	SCREW M5*8	4
21	P1105-0108B	C RING S-8	2
22	P1101-0904008AN	SCREW M4*8	4
23	P1101-0405012AN	SCREW M5*12	4
24	P1101-0204008AZ	SCREW M4*8	2
26	P1101-14040080	SCREW M4*8	12
A		BEARING FOLLOWER UNIT – FIG 30-1	2

**FIG. 11-1 ARCH SUPPORT UNIT**



<b>FIGURE 11-1 ARCH SUPPORT UNIT</b>			
<b>NO</b>	<b>PART NUMBER</b>	<b>Description</b>	<b>QTY</b>
1	P01-0611900	SUPPORT BRACKET	2
2	P1103-010512N	WASHER $\phi 5 \times 12$	6
3	P1104-020635ZZ2	BEARING 635ZZ	2
4	P1101-0505020AN	SCREW M5*20	2
5	P1103-0205Z	SPRING WASHER $\phi 5$	2
6	P1102-0105AZ	NUT M5	2



**FIG. 12-1 EJECT PIN UNIT**

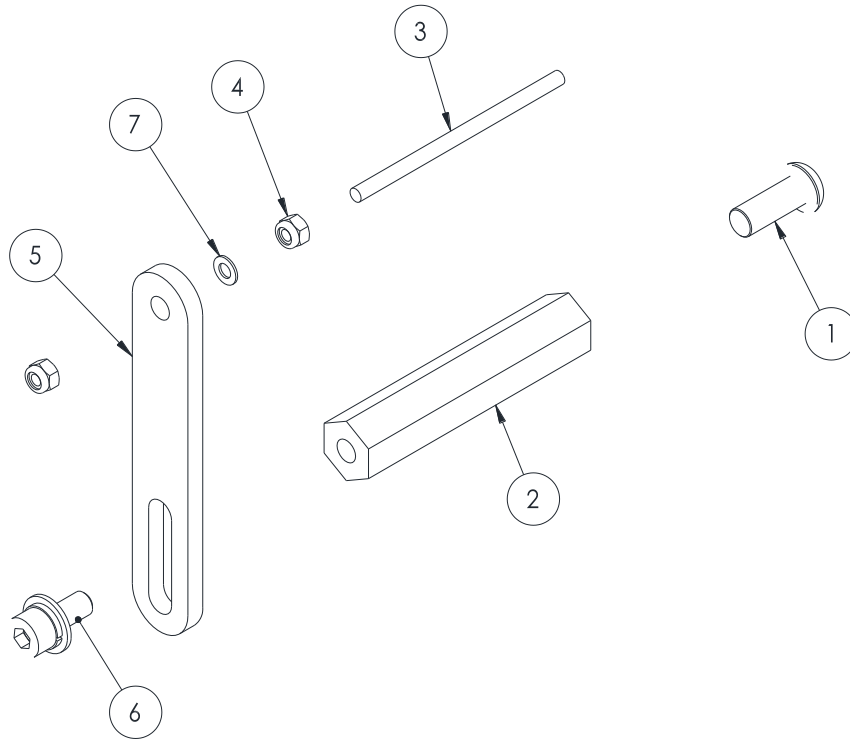
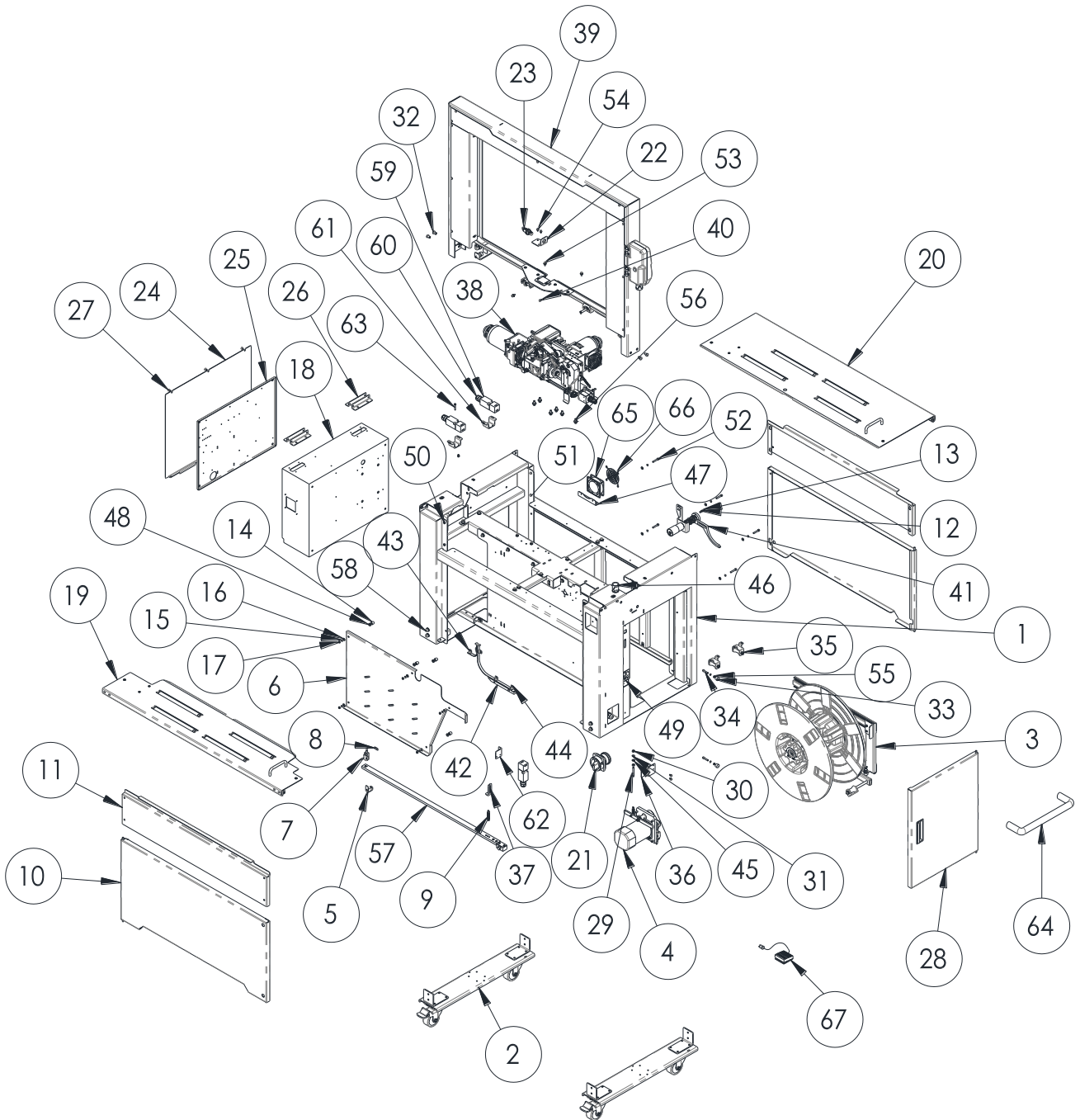


FIGURE 12-1 EJECT PIN UNIT			
NO	PART NUMBER	Description	QTY
1	P1101-0606016AN	SCREW M6*16	1
2	P02-0347800	SUPPORT	1
3	P02-034790A	EJECT PIN	1
4	P1102-0103BZ	NUT, M3	2
5	P01-0555400	PIN FIXER	1
6	P1101-0905012AN	SCREW M5*12	1
7	P1103-010306B5Z	WASHER M3*6*0.5	1

FIG. 13-1

MACHINE ASSEMBLY



**FIGURE 13-1 MACHINE ASSEMBLE**

<b>NO</b>	<b>PART NUMBER</b>	<b>Description</b>	<b>QTY</b>
1		MACHINE FRAME UNIT (W 850)	1
2		CASTER UNIT – FIG 1-1	2
3		DISPENSER UNIT – FIG 15-1	1
4		POOL FEED UNIT – FIG 2-1	1
5	P01-0575500	POOL LEVER STOPPER	1
6	P01-054954A	POOL COVER	1
7	P0319-S15834	PROXIMITY SWITCH QL-05N	1
8	P01-0041700	PROXIMITY SWITCH PLATE	1
9	P1202-0000100	SPRING	1
10	P01-0547920	DOOR	2
11	P01-0547820	UPPER COVER	2
12	P1103-0204Z	SPRING WASHER $\phi$ 4	4
13	P1101-0504010AN	SCREW M4*10	4
14	P06-0064610	POOL SPACER	4
15	P1103-0205Z	SPRING WASHER $\phi$ 5	12
16	P1103-010512N	WASHER $\phi$ 5*12	10
17	P1102-0105AN	NUT M5	5
18	P01-055090A	ELECTRICAL BOX	1
19		FRONT TABLE UNIT – FIG 4-1 (W 850)	1
20		REAR TABLE UNIT – FIG 5-1 (W 850)	1
21	P0311-010002800	MAIN POWER SWITCH	1
22	P01-0553500	TABLE SENSOR BRACKET	1
23	P0319-S15831	TABLE SENSOR	1
24	P01-0548200	ELECTRICAL BOX COVER	1
25	P01-055070A	ELECTRIC PLATE	1
26	P01-0551000	CABLE FIXER PLATE	4
27	P1101-0605006AN	SCREW M5*6	3
28		SIDE DOOR UNIT – FIG 16-1	1
29	P02-0338500	POOL SPRING ADJUST ROD	1
30	P1102-0106AZ	NUT M6	2
31	P1103-0206Z	SPRING WASHER $\phi$ 6	1
32	P1101-0608012AN	SCREW M8*12	4
33	P1106-020000100	SIDE DOOR MAGNET	2
34	P1101-0505025AN	SCREW M5*25	2

<b>FIGURE 13-1 MACHINE ASSEMBLE</b>			
<b>NO</b>	<b>PART NUMBER</b>	<b>Description</b>	<b>QTY</b>
35		POOL GUIDE ROLLER UNIT – FIG 7-1	2
36	P01-0553200	POOL FEED ADJUSTING PLATE	1
37	P01-0553300	POOL ADJUST PLATE	1
38		SEALER UNIT – FIG 20-1	1
39		ARCH UNIT – 850*600	1
40	P1101-0605010AN	SCREW M5*10	1
41		AUTO THREADING UNIT – FIG 6-1	1
42	P02-0340510	POOL GUIDE 850	1
43	P01-0549200	POOL GUIDE LEFT	1
44	P01-0549310	POOL GUIDE RIGHT	1
45	P1103-010612N	WASHER $\phi 6*12*1t$	1
46	P0401-0006000	CABLE FIXER	1
47	P01-0556300	FAN BRACKET	1
48	P06-0064630	POOL SPACER SMALL	5
49	P1001-0042500	POOL FEED INDICATE LABEL	1
50	P1101-0505012AN	SCREW 5*12	8
51	P1102-0105BZ	NUT M5	8
52	P1101-0505030AN	SCREW M5*30	5
53	P1101-0905012AN	SCREW M5*12	17
54	P1101-0904008AN	SCREW M4*8	5
55	P1102-0105AZ	NUT M5	2
56	P1101-0906016AN	SCREW M6*16	8
57		POOL SENSOR LEVER 850	1
58	P1101-0908020AN	SCREW M8*20	8
59	P0311-020000200	(OPTION) POWER CUT SWITCH	3
60	P0316-010000510	(OPTION) FIXED SEAT MG20AS-10SG	3
61	P01-0553600	(OPTION) POWER CUT FIX PLATE	2
62	P01-0553100	(OPTION) POWER CUT FIX PLATE	1
63	P1101-0104030AZ	(OPTION) SCREW M4*30	4
64	P1112-0002600	(OPTION) SIDE HANDLE $\phi 25*320$	1
65	P0319-S158402	FAN 220V	1
	P0319-S158401	FAN 110V	1
66	P0303-020000100	FAN NET	1
67	P0319-S15819	FOOT PEDAL SWITCH	1

**FIG. 14-1 POOL LEVER UNIT**

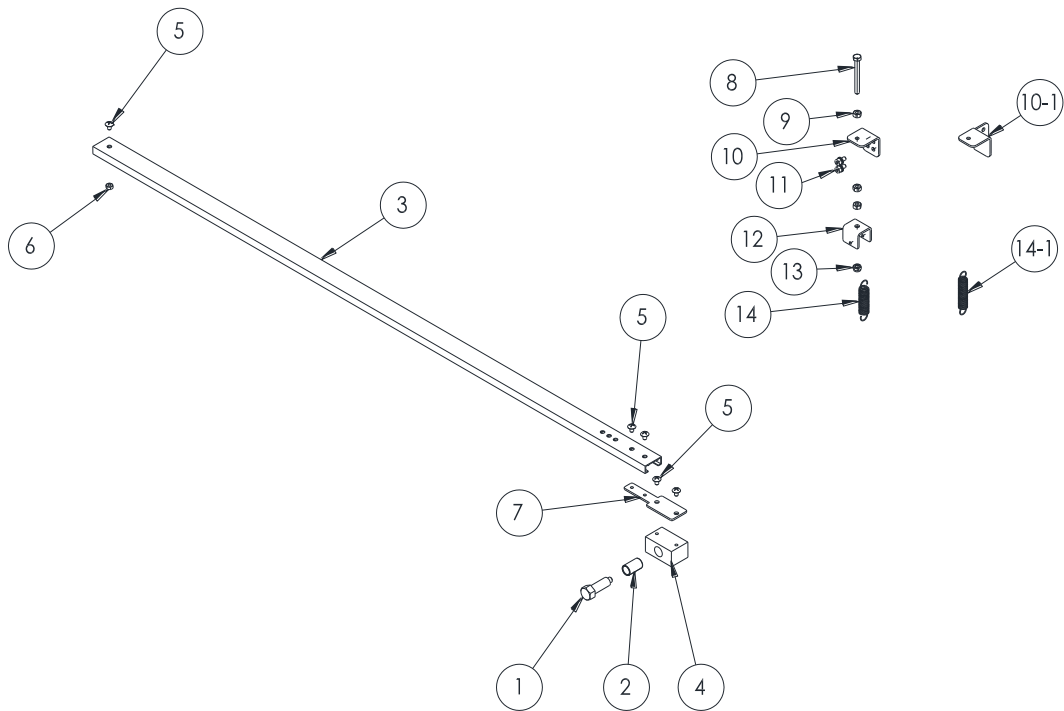
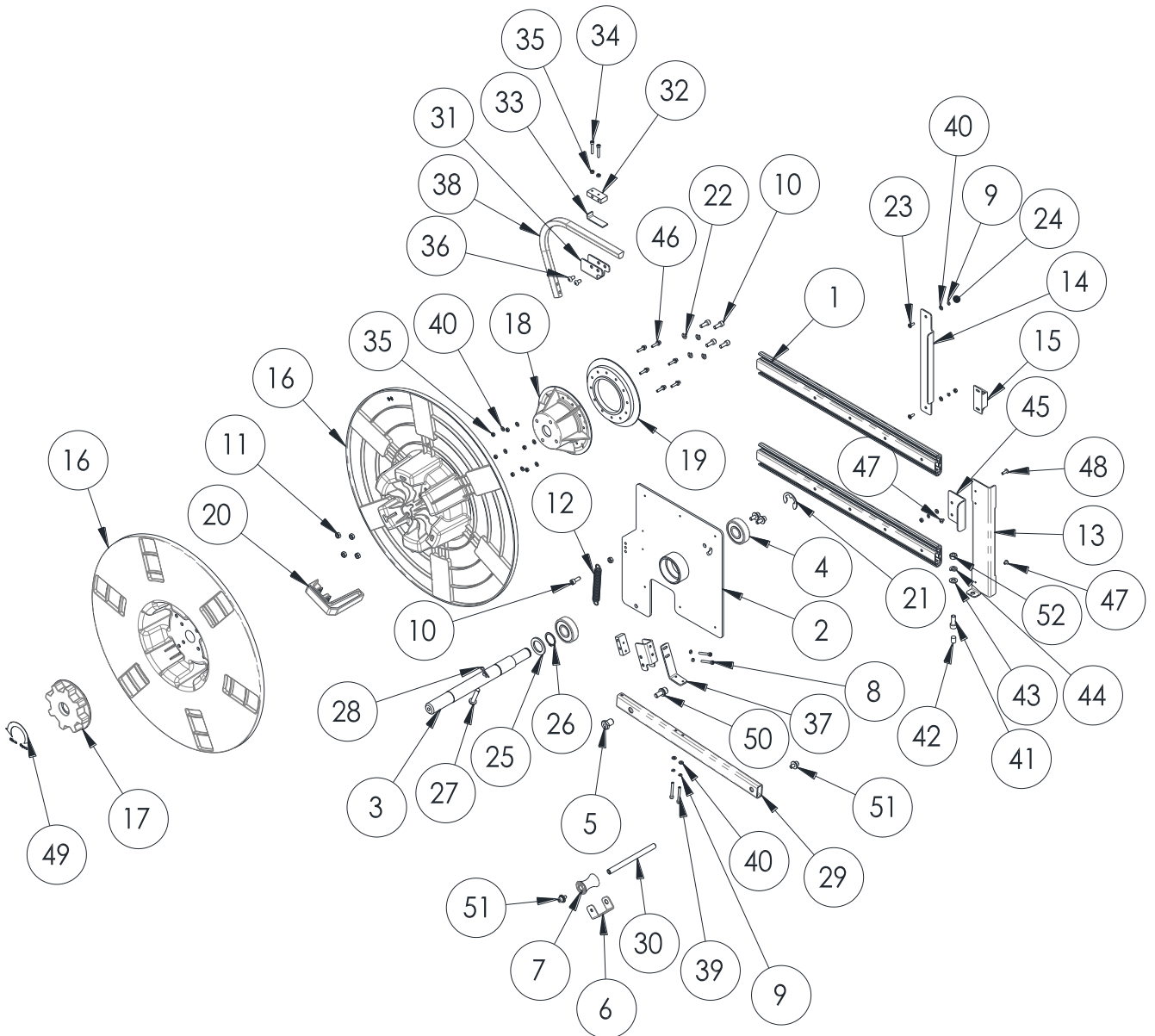


FIGURE 14-1 POOL LEVER UNIT			
NO	PART NUMBER	Description	QTY
1	P02-0348700	POOL LEVER SHAFT	1
2	P1104-0310201	BEARING CB1020	1
3	P02-0352720	POOL LEVER	1
4	P02-0352600	POOL LEVER FIXER	1
5	P1101-0104006AZ	SCREW M4*6	5
6	P1102-0104AN	HEX NUT M4	1
7	P01-0575400	POOL LEVER SUPPORT PLATE	1
8	P1101-1005045AZ	SCREW M5x45L	1
9	P1102-0105AN	HEX NUT M5	3
10	P01-0628500	FIX PLATE	1
10-1	P01-0628510	FIX PLATE (1250 WIDTH OR ABOVE)	1
11	P1101-0904008AN	SCREW M4x8L	2
12	P01-0628400	ADJUST PLATE	1
13	P1102-0105BZ	HEX NUT M5	1
14	P1202-0001200	SPRING	1
14-1	P1202-0000100	SPRING (850 WIDTH OR ABOVE)	1

FIG. 15-1

DISPENSER UNIT

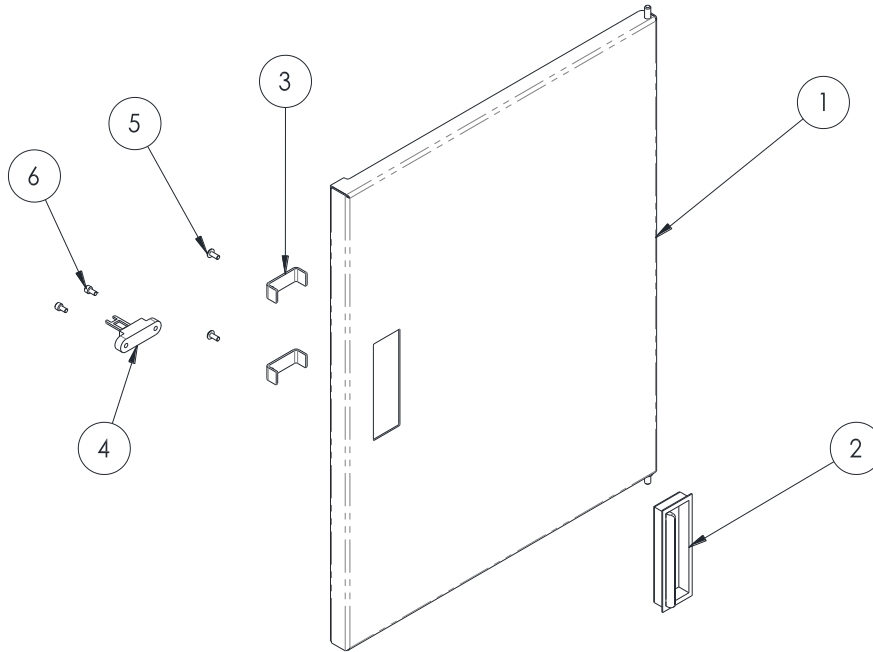


<b>FIGURE 15-1 DISPENSER UNIT</b>			
<b>NO</b>	<b>PART NUMBER</b>	<b>Description</b>	<b>QTY</b>
1	P1124-0001600	SLIDE	2
2	P01-055190D	DISPENSER SEAT	1
3	P02-033930A	DISPENSER SHAFT	1
4	P1104-026304ZZ0	BEARING, 6304ZZ	2
5	P02-0339400	BRAKE ARM SPACER	1
6	P01-0041200	PULLEY BRACKET	1
7	P06-000680C	PULLEY	1
8	P1101-0504030AN	SCREW M4*30	2
9	P1103-0204Z	SPRING WASHER $\phi$ 4	7
10	P1101-0506016AN	SCREW M6*16L	5
11	P1102-0106AN	NUT M6	5
12	P1202-0000400	SPRING	1
13	P01-0551700	SLIDE HANDLE	1
14	P01-055180B	FIXING PLATE	1
15	P1106-010000400	SIDE DOOR MAGNET	1
16	P06-0058200	DISPENSER	2
17	P06-0058100	DISPENSER KNOB	1
18	P06-0058300	DISPENSER CONNECT PULLEY	1
19	P06-0058400	BRAKE WHEEL	1
20	P06-0058500	(OPTION) EXTENSION CLAW	3
21	P1105-0319B	SNAP RING E19	1
22	P1103-0206Z	SPRING WASHER $\phi$ 6	4
23	P1101-0204012AZ	SCREW M4*12	2
24	P1102-0104AN	NUT M4	2
25	P01-0133100	DISPENSER SPACER	1
26	P1105-0125B	C RING S-25	1
27	P02-0076300	PIN	1
28	P1109-030801Z	PIN R-08	1
29	P01-0552000	BRAKE ARM	1
30	P02-0339500	PULLEY SHAFT	1
31	P01-0552100	BELT FIXER	2
32	P02-0339600	BELT FIX BLOCK	2

<b>FIGURE 15-1 DISPENSER UNIT</b>			
<b>NO</b>	<b>PART NUMBER</b>	<b>Description</b>	<b>QTY</b>
33	P01-0552200	PLATE	1
34	P1101-0504025AN	SCREW M4*25	2
35	P1102-0104AZ	NUT M4	9
36	P1101-0606010AN	SCREW M6*10	2
37	P01-0552300	BELT FIX PLATE	1
38	P0902-0008900	V-BELT	1
39	P1101-0504035AN	SCREW M4*35	2
40	P1103-010409N	WASHER $\psi$ 4	11
41	P1101-0906016AN	SCREW M6*16L	1
42	P06-000690A	CUSHION CAP	1
43	P1103-010612N	WASHER $\phi$ 6	1
44	P1103-0206Z	SPRING WASHER $\phi$ 6	1
45	P01-0585300	PULL HANDLE	1
46	P1101-0904018AN	SCREW M4*18	6
47	P1101-0104006AZ	SCREW M4*6	2
48	P1101-0104012AN	SCREW M4*12	1
49	P1001-0015900	DISPENSER STICKER	1
50	P1101-0908020AN	SCREW M8*20	1
51	P1101-0906012AN	SCREW M6*12	4
52	P1102-0106AZ	NUT M6	1

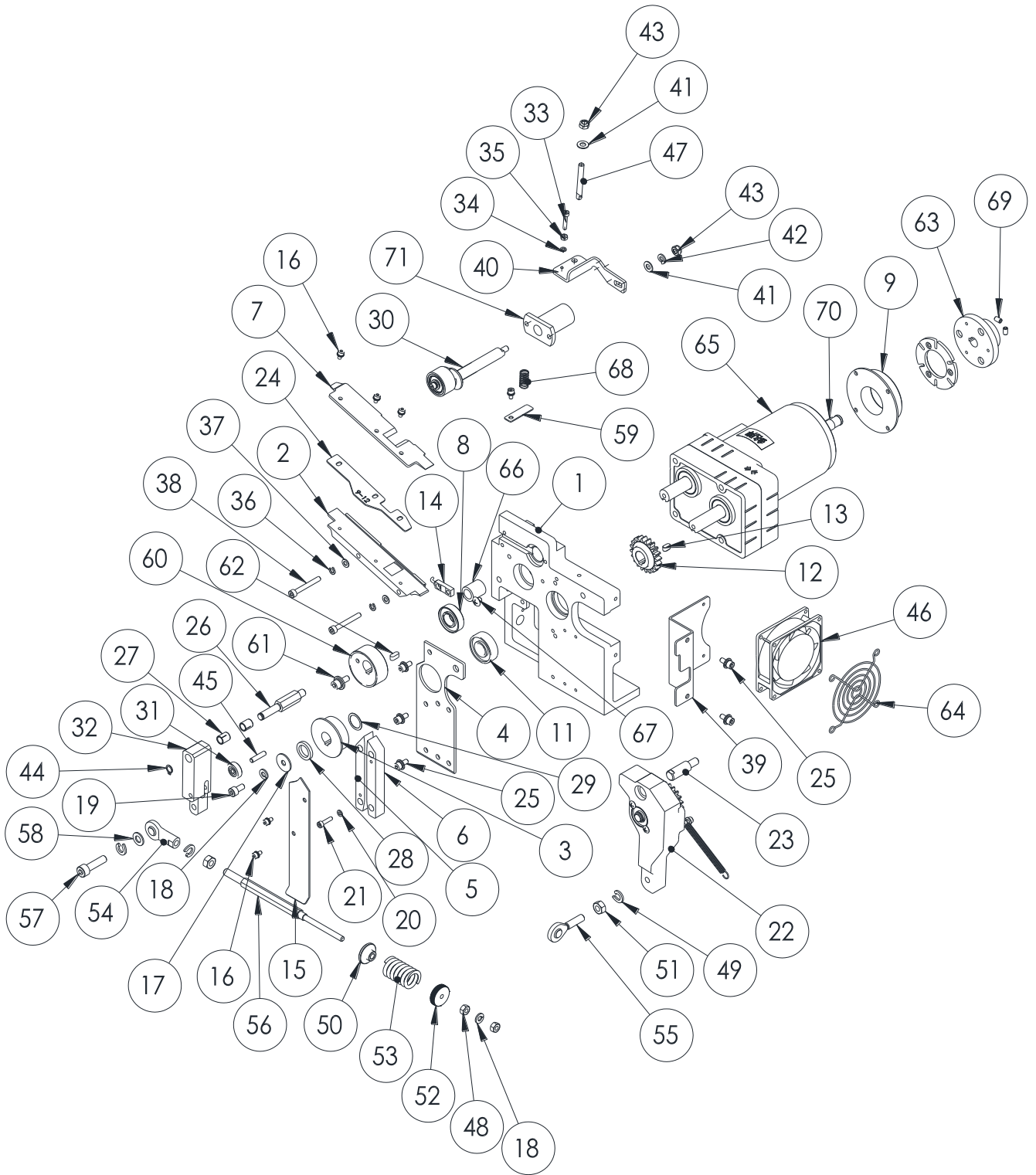


**FIG. 16-1      SIDE DOOR UNIT**



<b>FIGURE 16-1    SIDE DOOR UNIT</b>			
<b>NO</b>	<b>PART NUMBER</b>	<b>Description</b>	<b>QTY</b>
1	P01-0548100	SIDE DOOR	1
2	P1112-0000500	SIDE DOOR HANDLE	1
3	P01-0042000	HANDLE FIXER	2
4	P0311-030000100	(OPTION) CIRCUIT BREAKER KEY	1
5	P1101-0104010AZ	SCREW M4*10	2
6	P1101-0504008AN	SCREW M4*8	2

**FIG. 17-1 FEEDING UNIT**

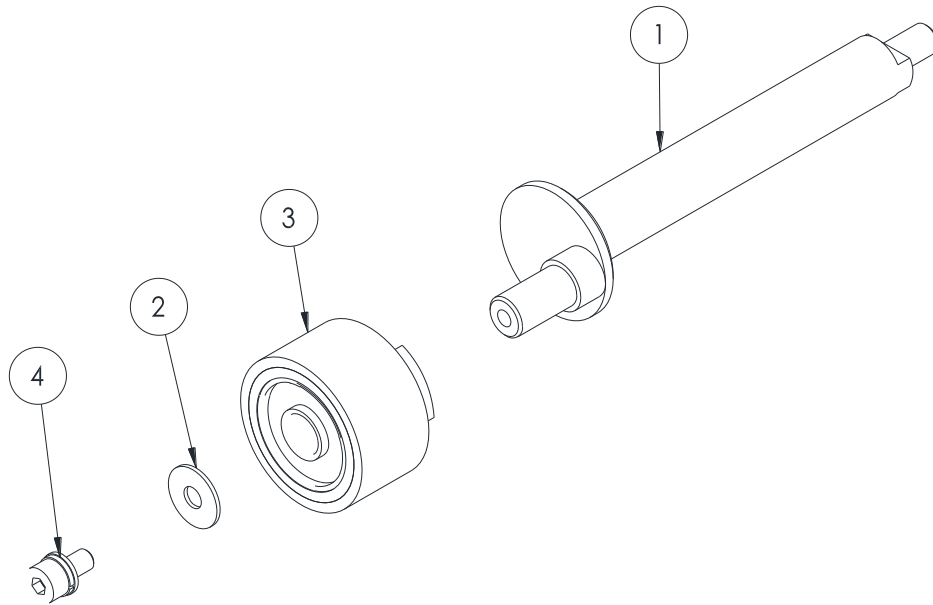


<b>FIGURE 17-1 FEEDING UNIT</b>			
<b>NO</b>	<b>PART NUMBER</b>	<b>Description</b>	<b>QTY</b>
1	P02-033670B	FEED SEAT	1
2	P02-033810A	FEED BANDWAY	1
3	P02-0337900	TENSION DRIVING ROLLER	1
4	P01-0558200	FEED SPACER PLATE	1
5	P02-0337700	GUIDE BLOCK LEFT	1
6	P02-0337800	GUIDE BLOCK RIGHT	1
7	P02-035100A	FEED BANDWAY COVER	1
8	P1104-026002ZZ3	BEARING	1
9	P0319-S15838	BRAKE	1
11	P1104-026202ZZ2	BEARING	1
12	P0701-0004800	TENSION GEAR	1
13	P1108-010505010G	KEY 5*5*10	1
14	P0319-S15832	LIMIT SWITCH	1
15	P01-055910A	GUIDE COVER	1
16	P1101-0904008AN	SCREW M4*8	6
17	P1103-01062102Z	WASHER M6x21x2t	1
18	P1103-0206Z	SPRING WASHER $\phi$ 6	2
19	P1101-0506012AN	SCREW M6*12L	1
20	P1103-0204Z	SPRING WASHER $\phi$ 4	4
21	P1101-0504016AN	SCREW M4*16L	4
22		TENSION UNIT – FIG 19-1	1
23	P02-0337400	TENSION ARM SHAFT	1
24	P01-055850B	BANDWAY ADJUST PLATE	1
25	P1101-0905012AN	SCREW M5*12	5
26	P02-0336800	TENSION CAM SHAFT	1
27	P1104-0308120	DRY BUSHING	2
28	P06-0065400	SPACER	1
29	P1103-011521B2C	WASHER $\psi$ 15*21*0.2	1
30		FEED DRIVEN UNIT – FIG 18-1	1

<b>FIGURE 17-1 FEEDING UNIT</b>			
<b>NO</b>	<b>PART NUMBER</b>	<b>Description</b>	<b>QTY</b>
31	P1104-020635ZZ2	BEARING	1
32	P02-0336900	TENSION CAM LEVEL	1
33	P1101-0504020AN	SCREW M4*20	1
34	P1103-0204Z	SPRING WASHER $\phi$ 4	1
35	P1102-0104AN	NUT M4	1
36	P1103-0205Z	SPRING WASHER $\phi$ 5	2
37	P1103-010510N	WASHER $\phi$ 5	2
38	P1101-0505040AN	SCREW M5*40	2
39	P01-0559200	FAN BRACKET	1
40	P01-055880B	ADJUSTMENT FIXING PLATE	1
41	P1103-010612N	WASHER $\phi$ 6*12*1t	2
42	P1103-0206Z	SPRING WASHER $\phi$ 6	1
43	P1102-0106BZ	NUT M6	2
44	P1105-0108B	C -RING S-8	1
45	P1109-0205022G	PIN 5*21.8MM	1
46	P0319-S158412	FAN AC230V	1
	P0319-S158411	FAN AC110V	1
47	P02-0338500	FEED FORCE ADJUSTING ROD	1
48	P1102-0106AN	NUT M6	2
49	P1103-0208Z	SPRING WASHER $\phi$ 8	3
50	P02-0337500	TENSION SPRING CAP	1
51	P1102-0108AZ	NUT M8	2
52	P02-0105400	TENSION ADJUST NUT	1
53	P1201-0004700	SPRING	1
54	P1104-060001600	ROD END	1
55	P1104-060001500	ROD END	1
56	P02-0337600	TENSION ADJUST LEVER	1
57	P1101-0508030AN	SCREW M8*30	1
58	P1103-010816N	WASHER $\phi$ 8*16	1

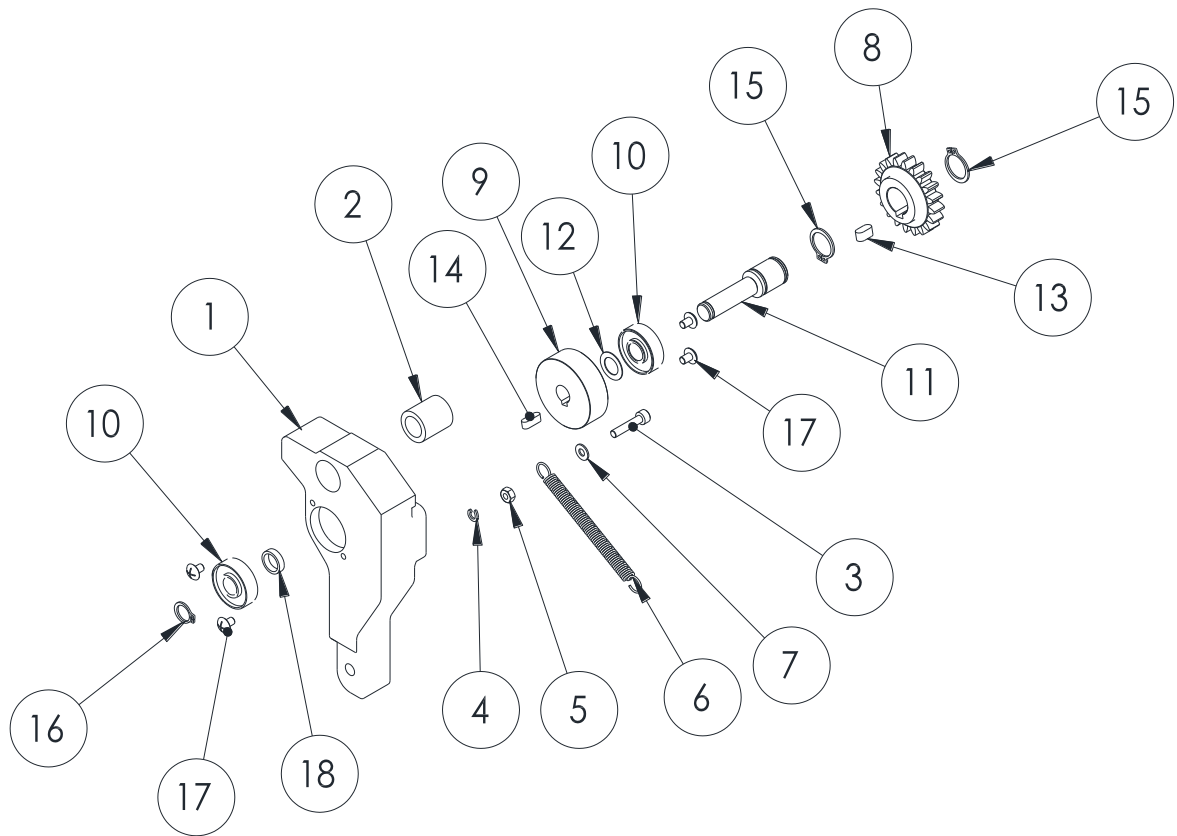
<b>FIGURE 17-1 FEEDING UNIT</b>			
<b>NO</b>	<b>PART NUMBER</b>	<b>Description</b>	<b>QTY</b>
59	P01-0559000	PLATE	1
60	P02-033800A	FEED DRIVING ROLLER	1
61	P1101-0906016AN	SCREW M6*16	1
62	P1108-010505012G	KEY 5*5*12	1
63	P02-0096300	BRAKE WHEEL	1
64	P0303-020000100	FAN COVER	1
65	P0503-0016900	M2 REDUCER MOTOR 110V 50HZ	1
	P0503-0017000	M2 REDUCER MOTOR 110V 60HZ	1
	P0503-0017100	M2 REDUCER MOTOR 220V 50HZ	1
	P0503-0017200	M2 REDUCER MOTOR 220V 60HZ	1
66	P02-0310400	BUSHING 12mm x 18mm x 20L	1
67	P1101-0105006AZ	SCREW M5*6	1
68	P1201-0010800	SPRING	1
69	P1101-0705008AB	SCREW M5*8	2
70	P1108-010404022G	KEY 4*4*22	1
71	P02-0397700	SLEEVE	1

**FIG. 18-1 FEED DRIVEN UNIT**



<b>FIGURE 18-1 FEED DRIVEN UNIT</b>			
<b>NO</b>	<b>PART NUMBER</b>	<b>Description</b>	<b>QTY</b>
1	P02-033820A	FEED ECCENTRIC SHAFT	1
2	P1103-010412N	WASHER $\phi 4*12$	1
3	P02-0338400	FEED DRIVEN ROLLER	1
4	P1101-0904008AN	SCREW M4*8	1

**FIG. 19-1 TENSION UNIT**



<b>FIGURE 19-1 TENSION UNIT</b>			
<b>NO</b>	<b>PART NUMBER</b>	<b>Description</b>	<b>QTY</b>
1	P02-0337100	TENSION SEAT	1
2	P02-0310400	BEARING	1
3	P1101-0504020AN	SCREW M4*20	1
4	P1103-0204Z	SPRING WASHER $\phi$ 4	1
5	P1102-0104AN	NUT M4	1
6	P1202-0012700	SPRING	1
7	P1103-010409N	WASHER $\psi$ 4*9	1
8	P0701-0004800	TENSION GEAR	1
9	P02-0337200	TENSION DRIVEN ROLLER	1
10	P1104-026000ZZ0	BEARING	2
11	P02-033730A	TENSION ARM SHAFT	1
12	P1103-011016B4S	WASHER $\psi$ 10* $\psi$ 16*0.4	1
13	P1108-010505010G	KEY 5*5*10	1
14	P1108-010404012G	KEY 4*4*12	1
15	P1105-0115B	C RING S-15	2
16	P1105-0110B	C RING S-10	1
17	P1101-0104006AZ	SCREW M4x6	4
18	P02-0338300	TENSION ROLLER SPACER	1







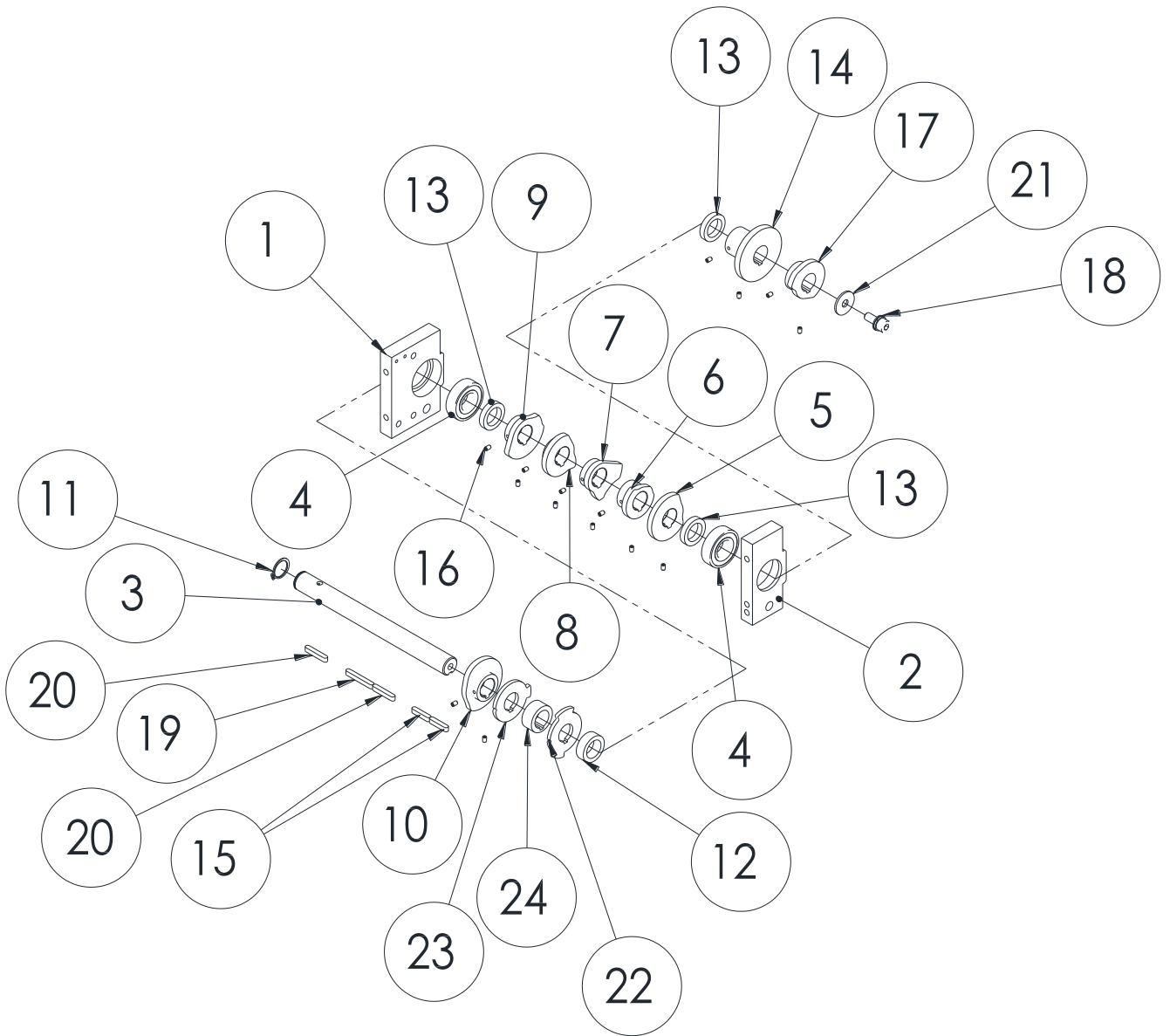
<b>FIGURE 20-1 SEALER UNIT</b>			
<b>NO</b>	<b>PART NUMBER</b>	<b>Description</b>	<b>QTY</b>
1	P1101-0504016AN	SCREW M4*16	2
2	P1101-0504016AN	SCREW M4*16	1
3	P1102-0104AZ	NUT M4	2
4	P02-0333700	SEALER SEAT	1
5	P02-033380B	SLIDING TABLE SUPPORT RIGHT	1
6	P02-033390B	SLIDING TABLE SUPPORT LEFT	1
7	P02-033400C	SLIDING TABLE	1
8		CAM UNIT – FIG 21-1	1
9		SEPERATOR UNIT – FIG 23-1	1
10	P01-055650A	SLIDING TABLE SPRING BRACKET	1
11	P06-0065300	CUSHION	2
12	P02-0336400	MOTOR SUPPORT	4
13		FEEDING UNIT – FIG 17-1	1
14	P0501-0018800	CAM REDUCER MOTOR (200-240V/60 135W)	1
	P0501-0018700	CAM REDUCER MOTOR (100-120V/60 135W)	1
	P0501-0020900	CAM REDUCER MOTOR (100-120V/50 135W)	1
	P0501-0021000	CAM REDUCER MOTOR (200-240V/50 135W)	1
15		HEATER PLATE UNIT – FIG 24-1	1
16		SEPERATOR ARM UNIT – FIG 29-1	1
17	P02-0334800	SHAFT - HEATER	1
18	P02-0334400	SHAFT - ARM	1
19	P1103-010612N	WASHER $\phi$ 6	4
20	P1103-0206Z	SPRING WASHER $\phi$ 6	4
21	P1101-0506080AN	SCREW M6*80	2
22	P1101-0506060AN	SCREW M6*80	2
23		ARCH OPENER UNIT – FIG 25-1	1
24	P0319-S158422	FAN 220V	1
	P0319-S158421	FAN 110V	1
25	P1202-0011400	SEPERATING ARM SPRING	1
26	P1102-01081N	NUT M8	1
27	P1103-0208Z	SPRING WASHER $\phi$ 8	1
28	P1103-010816N	WASHER $\phi$ 8*16	1

<b>FIGURE 20-1 SEALER UNIT</b>			
<b>NO</b>	<b>PART NUMBER</b>	<b>Description</b>	<b>QTY</b>
29	P02-0336500	ARCH OPENER SHAFT	1
30	P1103-010816N	WASHER $\phi$ 8*16	2
31	P1103-0208Z	SPRING WASHER $\phi$ 8	4
32	P1101-1008030AHZ	SCREW M8*30	2
33	P0319-S15837	BRAKE	1
34	P02-0096300	BRAKE WHEEL	1
35	P06-0065300	CUSHION	2
36	P1202-0010600	SPRING	2
37	P1104-0308080	BEARING	1
38	P01-055780B	REFEEDING LEVER	1
39	P1104-020635ZZ2	BEARING	1
40	P1101-1005016AZ	SCREW M5*16	1
41	P1103-0205Z	SPRING WASHER $\phi$ 5	1
42	P02-0337000	REFEEDING LEVER SHAFT	1
43	P01-0557600	FAN SEAT	1
44	P1105-0309B	E9- RING	3
45	P1101-0705008AB	SCREW M5*8	4
46	P01-0557300	LIMIT PLATE	2
47	P1101-0604006AN	SCREW M4*6	2
48	P01-0556400	SEALER SEAT PLATE	1
49	P1101-0405010AN	SCREW M5*10	2
50	P1202-0012700	FEED SPRING	1
51	P1101-0905012AN	SCREW M5*12	1
52	P1101-0505045AN	SCREW 5*45	1
53	P1103-0205Z	SPRING WASHER $\phi$ 5	3
54	P1102-0105AN	NUT M5	1
55	P0319-S15839	SOLENOID	1
56	P01-0553400	SOLENOID SEAT	1
57	P02-0338600	SOLENOID PUSHER	1
58	P01-055750A	TABLE SUPPORT RIGHT	1

<b>FIGURE 20-1 SEALER UNIT</b>			
<b>NO</b>	<b>PART NUMBER</b>	<b>Description</b>	<b>QTY</b>
59	P06-006500A	CUSHIONG M8	2
60	P1101-0508025AN	SCREW M8*25	2
61	P1102-0108AZ	NUT M8*12MM	2
62	P01-055740A	TABLE SUPPORT LEFT	1
63	P1103-010512N	WASHER $\phi$ 5*12	2
64	P1101-0505020AN	SCREW M5*20L	2
65	P02-0336600	ARCH OPENER FIXER	1
66	P0303-020000100	FAN COVER	1
67	P1101-0104035AZ	SCREW M4*35	2
68	P1103-0204Z	SPRING WASHER $\phi$ 4	3
69	P1102-0104AN	NUT M4	4
70	P1101-0904008AN	SCREW M4*8	6
71		CLAMP SEAT UNIT – FIG 22-1	1
72	P1102-0104AZ	NUT M4	1
73	P1103-0206Z	SPRING WASHER $\phi$ 6	12
74	P1101-0506016AN	SCREW M6*16	4
75	P1108-010404022G	KEY 4*4*22	1
76	P1101-0506070AN	SCREW M6*70	3
77	P1103-010612N	WASHER $\phi$ 6*12*1t	8
78	P1101-0506065AN	SCREW M6*65	1
79	P1101-0506085AN	SCREW M6*85	4
80	P1101-0104030AZ	SCREW M4*30	2
81	P01-0612400	SENSOR SEAT	1
82	P01-0612300	SENSOR SEAT	1
83	P0302-010000400	PROX. SENSOR PL-05N	2

FIG. 21-1

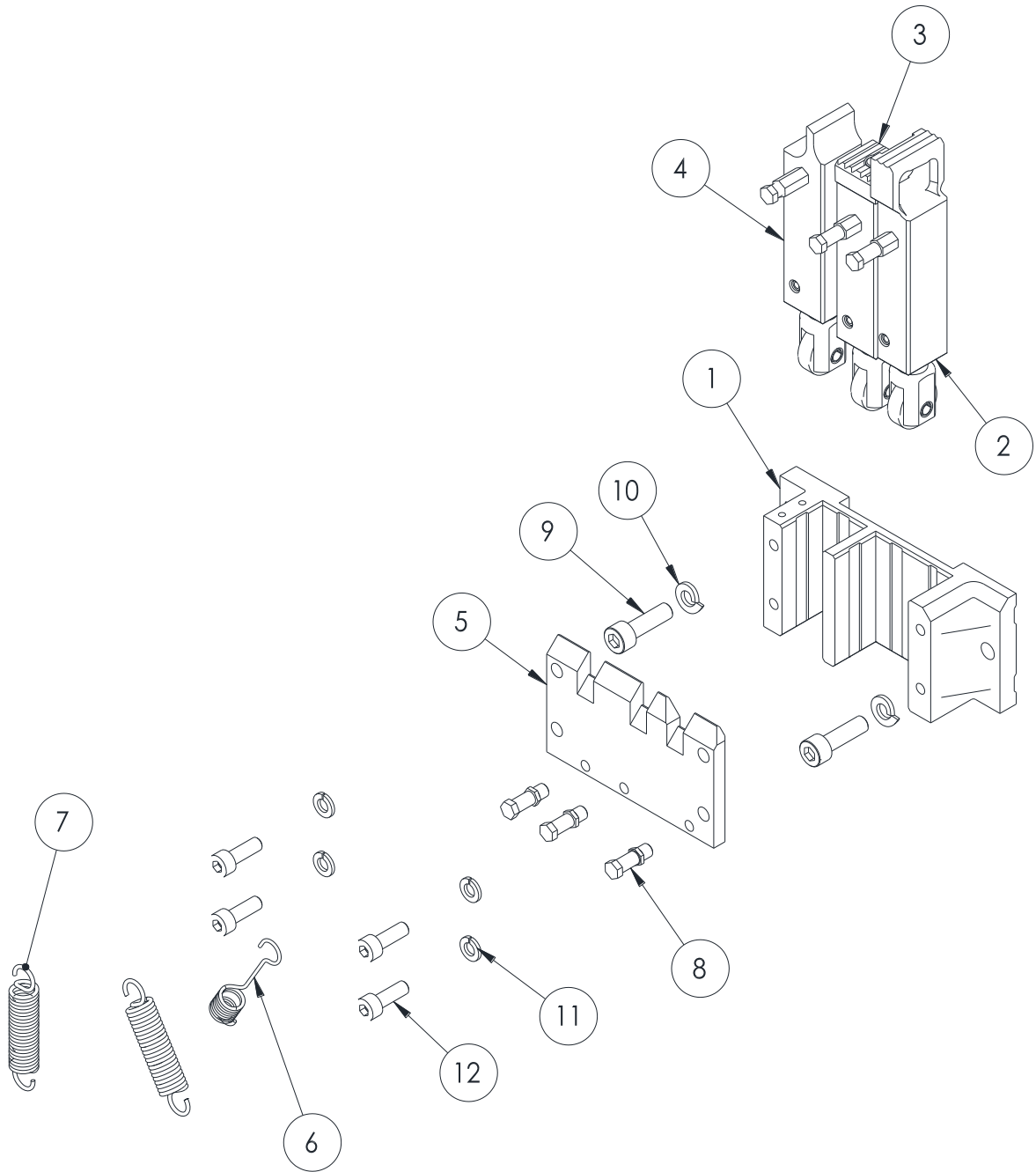
CAM UNIT



<b>FIGURE 21-1 CAM UNIT</b>			
<b>NO</b>	<b>PART NUMBER</b>	<b>Description</b>	<b>QTY</b>
1	P02-0335400	BEARING SEAT LEFT	1
2	P02-0336100	BEARING SEAT RIGHT	1
3	P02-0334900	CAM SHAFT	1
4	P1104-026004ZZ1	BEARING	2
5	P02-0336000	CAM (HEATING)	1
6	P02-0335900	CAM (END-GRIPPER)	1
7	P02-0335800	CAM (WELDING CLAMP)	1
8	P02-0335700	CAM (SLIDING TABLE)	1
9	P02-0335600	CAM (HOLDING GRIPPER)	1
10	P02-0335000	CAM (ARCH)	1
11	P1105-0120B	C RING S-20	1
12	P02-0335300	SPACER	1
13	P02-0335500	SPACER SMALL	3
14	P02-0336200	CAM (TENSION)	1
15	P1108-010505025G	KEY 5x5x25L	2
16	P1101-0704006AB	SCREW M4*6	1
17	P02-033630A	CAM (REFEED FORCE)	1
18	P1101-0908020AN	SCREW M8*20	1
19	P1108-010505038G	KEY 5x5x38L	1
20	P1108-010505030G	KEY 5x5x30L	2
21	P01-0559300	WASHER M8	1
22	P01-0612100	CAM (REFEED)	1
23	P01-0612200	CAM (ZERO POSITION)	1
24	P02-0360400	CAM SPACER	1

FIG. 22-1

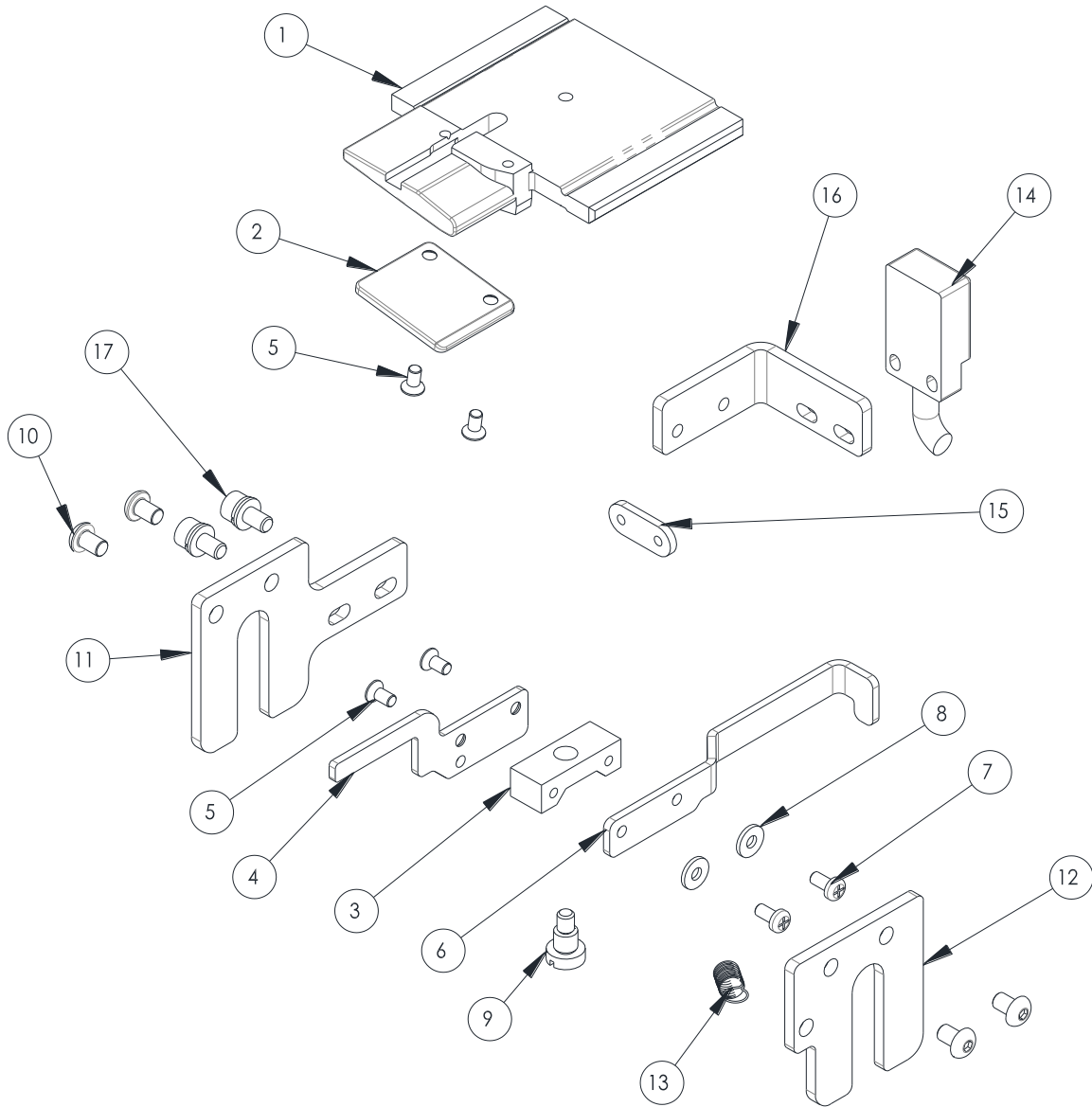
CLAMP SEAT UNIT



<b>FIGURE 22-1 CLAMP SEAT UNIT</b>			
<b>NO</b>	<b>PART NUMBER</b>	<b>Description</b>	<b>QTY</b>
1	P02-033330A	CLAMP SEAT	1
2	P02-0361800	END GRIPPER UNIT	1
3	P02-0361900	WELDING CLAMP UNIT	1
4	P02-0362000	HOLDING GRIPPER UNIT	1
5	P02-033340A	CLAMP SEAT COVER	1
6	P1202-0011300	SPRING	1
7	P1202-0009100	SPRING	2
8	P02-0333600	SCREW	3
9	P1101-0506020AN	SCREW M5x10	2
10	P1103-0206Z	SPRING WASHER $\phi$ 6	2
11	P1103-0205Z	SPRING WASHER $\phi$ 5	4
12	P1101-0505015AN	SCREW M5x15	4



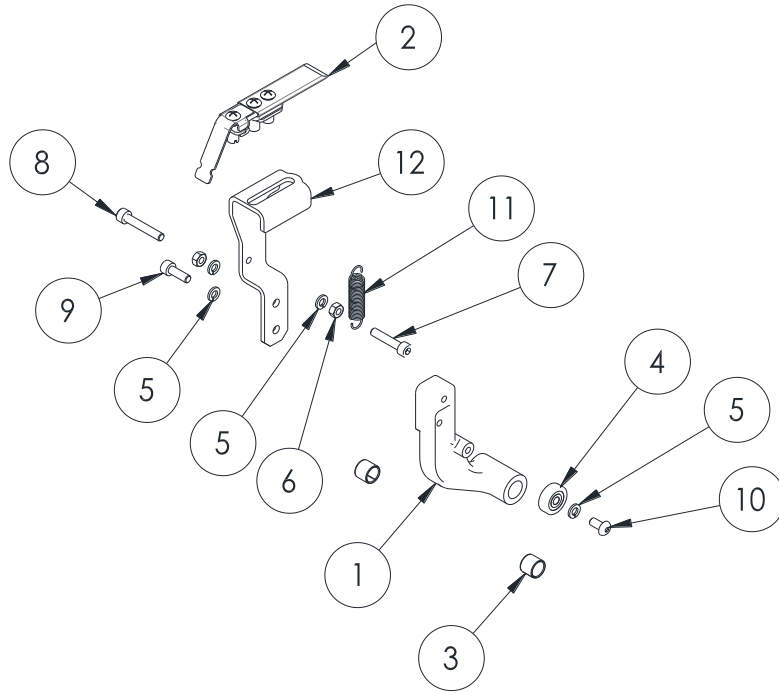
**FIG. 23-1**      **SEPARATING PLATE UNIT**



<b>FIGURE 23-1 SEPARATING PLATE UNIT</b>			
<b>NO</b>	<b>PART NUMBER</b>	<b>Description</b>	<b>QTY</b>
1	P02-033410A	SEPARATOR	1
2	P01-0556700	SEPARTOR GUIDE PLATE	1
3	P02-033420B	ACTUATOR FIXER	1
4	P01-055660B	ACTUATOR	1
5	P1101-0203006AZ	SCREW M3x6	2
6	P01-0642500	DETECTOR PLATE	1
7	P1101-0303006AZ	SCREW M3x6	2
8	P1103-01030801Z	WASHER $\phi$ 3	2
9	P01-0042800	BUSHING	1
10	P1101-0604006AN	SCREW M4X6	4
11	P01-058770C	SEPERATOR PLATE FIXER LFFT	1
12	P01-058780A	SEPERATOR PLATE FIXER RIGHT	1
13	P1202-0013100	PROX. DETECTOR SPRING	1
14	P0319-S15833	PROXIMITY SWITCH	1
15	P01-0631500	PROXIMITY PLATE FIXER	1
16	P01-0642600	PROXIMITY PLATE	1
17	P1101-0904008AN	SCREW M4*8	2

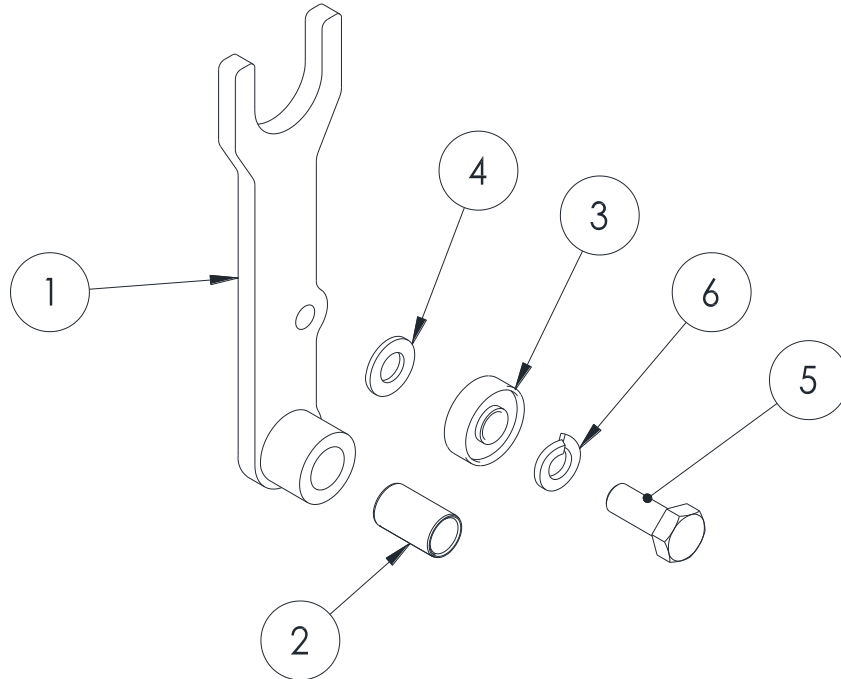


**FIG. 24-1 HEATER PLATE UNIT**



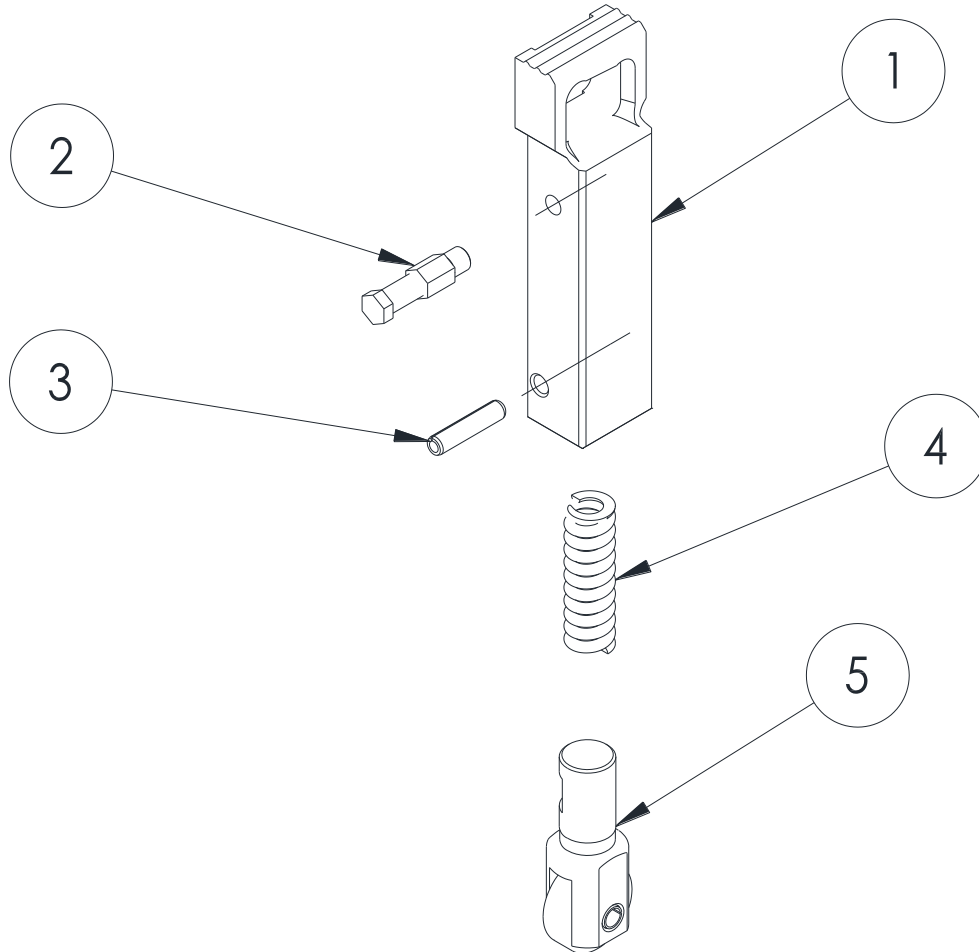
<b>FIGURE 24-1 HEATER PLATE UNIT</b>			
<b>NO</b>	<b>PART NUMBER</b>	<b>Description</b>	<b>QTY</b>
1	P02-0334500	HEATER ARM	1
2	P02-0361700	HEATER PLATE ASSEM	1
3	P1104-0310101	BEARING CB1010	2
4	P1104-020635ZZ2	BEARING 635ZZ	1
5	P1103-0205Z	SPRING WASHER φ5	4
6	P1102-0105AZ	NUT M5	2
7	P1101-0505025AN	SCREW M5*25	1
8	P1101-0505030AN	SCREW M5*30	1
9	P1101-0505015AN	SCREW M5*15	1
10	P1101-0605010AN	SCREW M5*10	1
11	P1202-0001000	SPRING	1
12	P01-0557000	SPRING SEAT	1

**FIG. 25-1 ARCH OPENER UNIT**



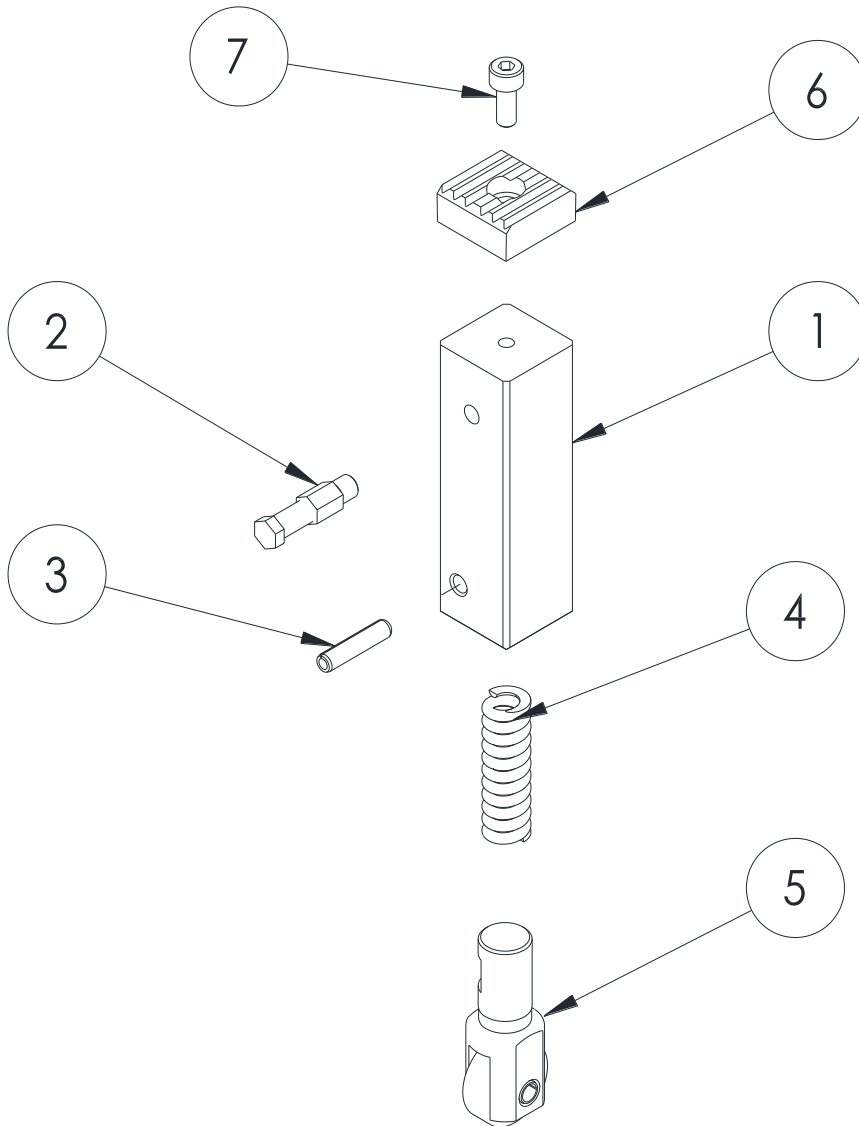
<b>FIGURE 25-1 ARCH OPENER UNIT</b>			
<b>NO</b>	<b>PART NUMBER</b>	<b>Description</b>	<b>QTY</b>
1	P01-055770A	ARCH OPENER	1
2	P1104-0310201	BEARING CB1020	1
3	P1104-020608ZZ0	BERRING 608ZZ(CWB)	1
4	P1103-010816C5Z	WASHER M8*16*1.5T	1
5	P1101-1008020CZ	SCREW M8*20	1
6	P1103-0208Z	SPRING WASHER φ8	1

**FIG. 26-1 END GRIPPER UNIT**



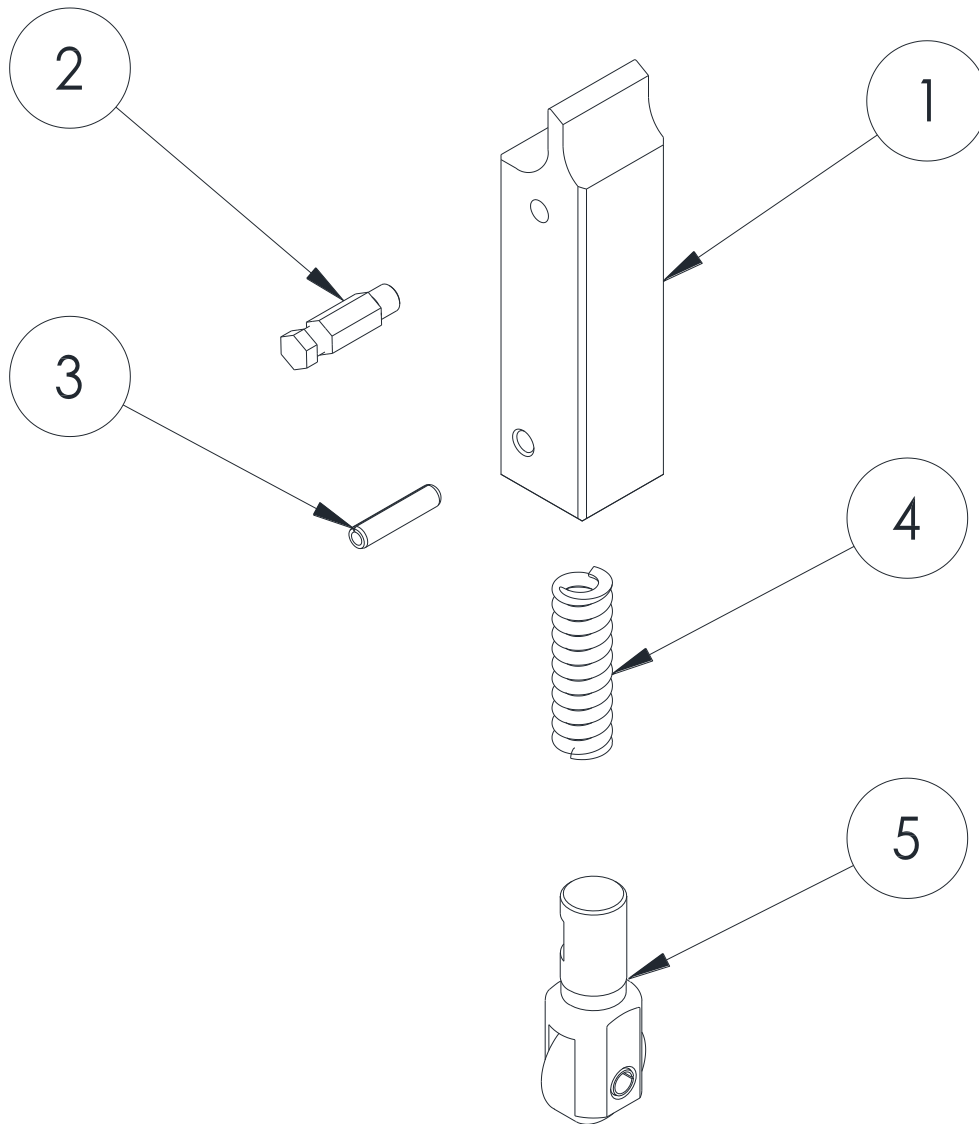
<b>FIGURE 26-1 END GRIPPER UNIT</b>			
<b>NO</b>	<b>PART NUMBER</b>	<b>Description</b>	<b>QTY</b>
1	P02-033290A	END GRIPPER	1
2	P02-0333500	HOOK BOLT	1
3	P1109-0104018B	SPRING PIN, 4 X 18L	1
4	P1201-0004600	COMPRESSION SPRING	1
5	P02-0363200	CAM FOLLOWER UNIT	1

**FIG. 27-1 WELDING CLAMP UNIT**



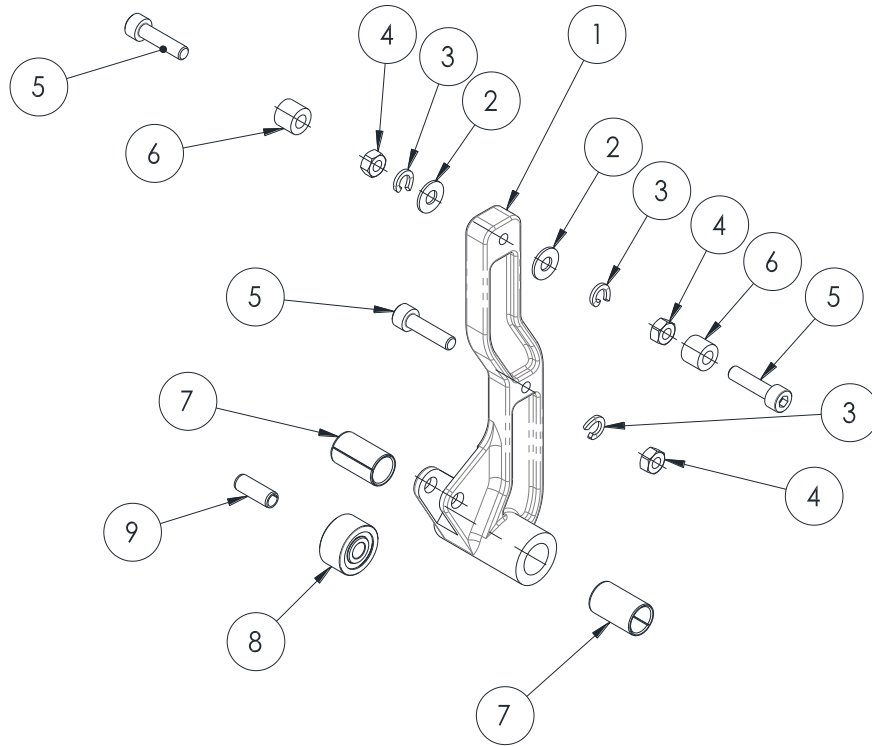
<b>FIGURE 27-1 WELDING CLAMP UNIT</b>			
<b>NO</b>	<b>PART NUMBER</b>	<b>Description</b>	<b>QTY</b>
1	P02-033300A	WELDING CLAMP	1
2	P02-0333500	HOOK BOLT	1
3	P1109-0104018B	SPRING PIN 4 X 18L	1
4	P1201-0004600	COMPRESSION SPRING	1
5	P02-0363200	CAM FOLLOWER UNIT	1
6	P02-0333200	CUTTER LOWER	1
7	P1101-0504010AN	SCREW M4 X 10	1

**FIG. 28-1 HOLDING GRIPPER UNIT**



<b>FIGURE 28-1 HOLDING GRIPPER UNIT</b>			
<b>NO</b>	<b>PART NUMBER</b>	<b>Description</b>	<b>QTY</b>
1	P02-033310A	HOLDING GRIPPER	1
2	P02-0076600	HOOK BOLT	1
3	P1109-0104018B	SPRING PIN 4 X 18L	1
4	P1201-0004600	SPRING	1
5	P02-0363200	CAM FOLLOWER UNIT	1

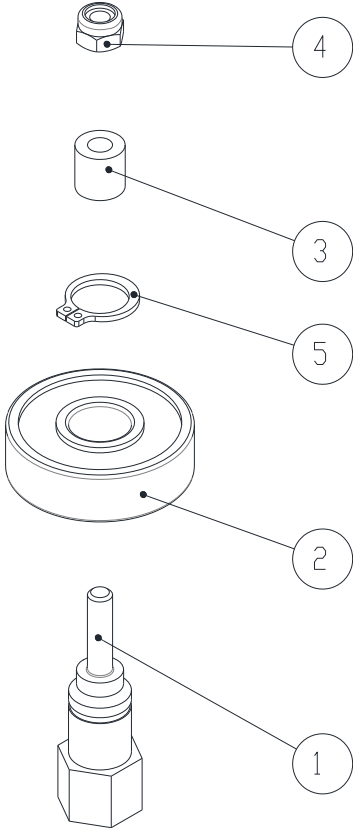
**FIG. 29-1 SEPERATOR ARM UNIT**



<b>FIGURE 29-1 SEPERATOR ARM UNIT</b>			
<b>NO</b>	<b>PART NUMBER</b>	<b>Description</b>	<b>QTY</b>
1	P02-0334300	SEPERATOR ARM	1
2	P1103-010512N	WASHER $\phi 5 * 12$	2
3	P1103-0205Z	SPRING WASHER $\phi 5$	3
4	P1102-0105AZ	NUT M5	3
5	P1101-0505020AN	SCREW M5 X 20	3
6	P02-0025400	BUSH	2
7	P1104-0310201	BUSHING CB 1020	2
8	P1104-05NAST6ZZ0	BEARING	1
9	P1109-0106016B	SPRING PIN 6 X 16	1

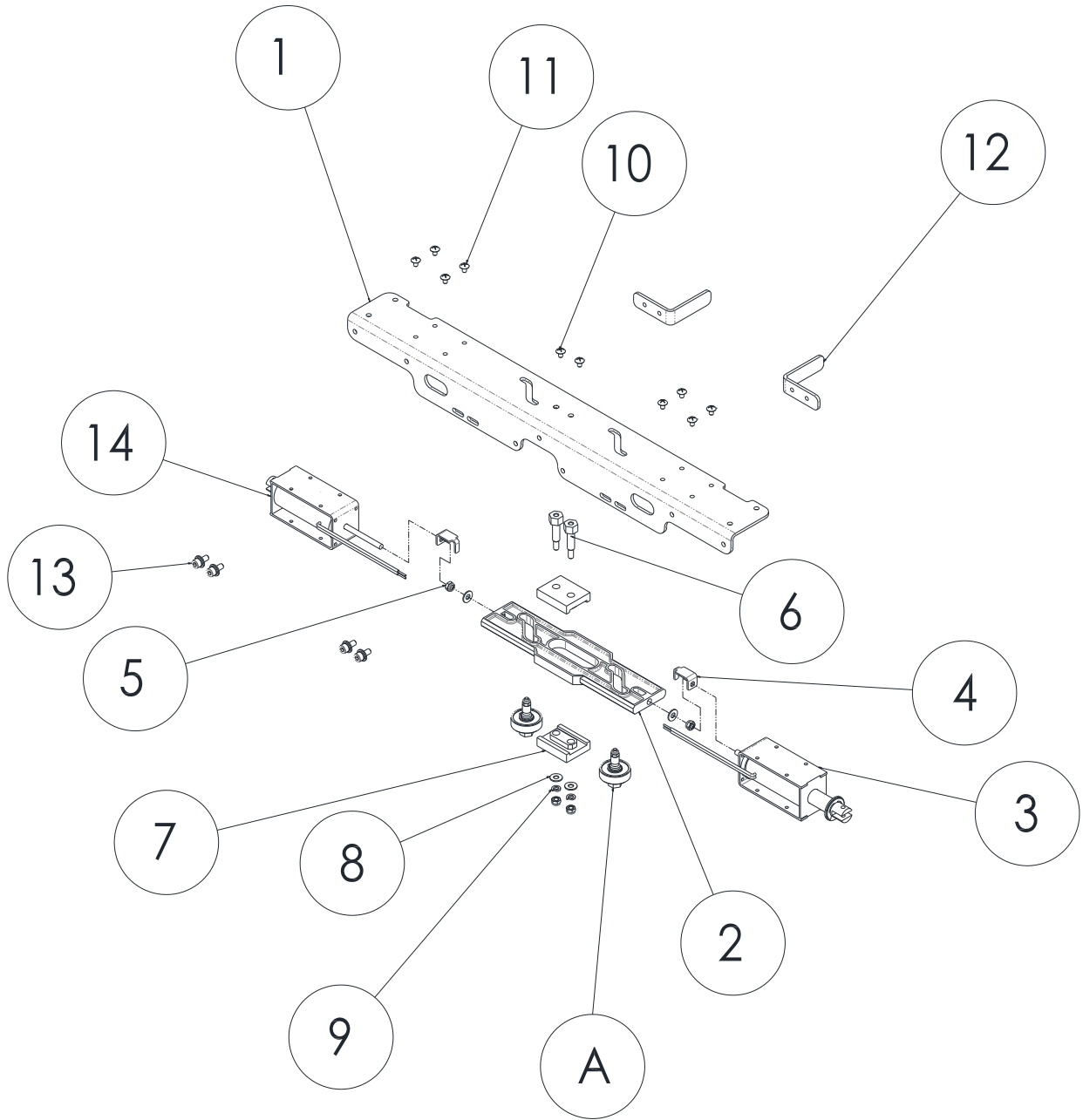


**FIG. 30-1 BEARING FOLLOWER UNIT**



<b>FIGURE 30-1 BEARING FOLLOWER UNIT</b>			
<b>NO</b>	<b>PART NUMBER</b>	<b>Description</b>	<b>QTY</b>
1	P02-034850A	BEARING SEAT	1
2	P1104-026200ZZ0	BEARING	1
3	P1104-05HK04080	BEARING	1
4	P1102-0104BZ	NUT M4	1
5	P1105-0110B	C CLIP	1

**FIG. 31-1 UPPER ARCH OPEN UNIT**



<b>FIGURE 31-1 UPPER ARCH OPEN UNIT</b>			
<b>NO</b>	<b>PART NUMBER</b>	<b>Description</b>	<b>QTY</b>
A		BEARING FOLLOWER UNIT – FIG 30-1	2
1	P01-054980C	SOLENOID FIX PLATE	1
2	P06-006510B	GUIDE	1
3		ARCH OPENING SOLENOID	1
4	P01-0640000	LIMIT PLATE	2
5	P1102-0105BZ	NUT M5	4
6	P02-0400600	GUIDE FIXER SHAFT	2
7	P06-0075700	GUIDE BLOCK	2
8	P1103-010512N	WASER 5	4
9	P1103-0205Z	SPRING WASHER 5	2
10	P1101-0605010AN	SCREW M5*10	2
11	P1101-0104006AZ	SCREW M4*6L	8
12	P01-0549700	PLATE	2
13	P1101-0905012AN	SCREW M5*12	4
14		ARCH CLOSING SOLENOID	1

